

DX News

Serving DX'ers since 1933



Volume 68, No. 15 - January 22, 2001 (ISSN 0737-1659)

Inside ...

- 2 .. AM Switch
- 3 .. DDXD
- 18 .. IDXD
- 20 .. DX'er's Notebook

- 26 .. Target DX
- 28 .. Confirmed DX'er
- 30 .. GYDXA-1230
- 35 .. DXP-2 Phasing Unit
- 42 .. Not quite a Musing, but ...

CPC Test Calendar

WILM	DE	1450	Feb. 4	0000-0200
WFBS	PA	1280	Feb. 17	0000-0200

WFBS-1280 -(114 Market Street - Berwick, PA 18603) will conduct a DX test Saturday, February 17, from 0000-0200. The test will include tones, music, code and voice ID's on 1000 watts daytime power, non-directional. Phone calls (no collect) accepted at 570-752-8012. Reports with return postage may be sent to Kevin Fennessey. Arranged by Dave Schmidt (who will do the test!) for the National Radio Club.

From the Publisher ... Winter doldrums are here, along with that nasty old flu, so it's time to bundle up and take advantage of the hot DX that others are reporting!

We're slowly getting caught up on back articles and columns, but I can foresee slack times ahead. If you've been holding back on that Musing or little construction article, now's the time to get it in. Don't forget to check out our submission guide before typing it up, though, to save YOU some time and US some grief. The guide is available on <<www.nrcdxas.org>>, or I'd be happy to send you a copy for an SASE (business size envelope, please).

DXN Publishing Schedule, Volume 68

Iss.	Deadline	Pub. Date	Iss.	Deadline	Pub. Date
16.	Jan. 19	Jan. 29	24.	Mar. 30	Apr. 9
17.	Jan. 26	Feb. 5	25.	Apr. 6	Apr. 16
18.	Feb. 2	Feb. 12	26.	May 4	May 14
19.	Feb. 9	Feb. 19	27.	June 1	June 10
20.	Feb. 16	Feb. 26	28.	July 6	July 16
21.	Feb. 23	Mar. 5	29.	Aug. 3	Aug. 13
22.	Mar. 2	Mar. 12	30.	Sept. 7	Sept. 17
23.	Mar. 16	Mar. 26			

DX Time Machine

From the pages of DX News:

50 years ago ... from the January 20, 1951 DXN: Steve Mann, Westbury, NY reported that CB106 received 21 reports as the result of their DX broadcast on November 13, the most distant coming from Clarence Mustoc, Spokane, WA; also reported by Steve were veries from SBH and 4VW.

25 years ago ... from the January 12, 1976 DXN: Conrad Durocher, Saugus, MA reported hearing WLAM-1470 and WAAB-1440 on his newly-aligned NC-109.

10 years ago ... from the January 21, 1991 DXN: Subscription Center Manager Ron Museo reported receiving subscription renewal checks made out to him instead of the NRC ... Jay Smilkstein, Mt. Kisco, NY was looking for a Realistic TM-1000 tuner; a McKay-Dymek AM5 tuner; a PRD-1 RDF R1511; and radio catalogs, books, and magazines.

For Beginners ...

the world of DX'ing can be confusing, but both new and experienced DX'ers can find answers in Russ Edmunds' column, "Target DX." If you have a DX question, just send it to Russ at <<wb2bjh@nrcdxas.org>> or 753 Valley Rd. - Blue Bell, PA 19422-2052 and he'll answer it in a future column. Remember - you're not alone - we all started at the beginning - once!

Facts About NRC's DX Audio Service

The DX Audio Service provides the ONLY monthly broadcast news cassette service to the DX community. Available to anyone, anywhere, it is designed to inform the radio listener in a pleasing and informative manner. Many of the announcers on the service are professional broadcasters giving their free time to give the listener the finest service available.

DXAS was started to provide broadcast information, both AM and FM, to the visually-handicapped DX listener. It has evolved into a service which provides useful material to all types of listeners. Many subscribers listen to the tape to and from their place of work while driving. Features include not only news about DX, but also airchecks from radio markets, dialscans, frequency scans, and other items.

A one-year subscription is only \$25. Sample 45-minute copy: \$2.00; back issues of DXAS: \$3.

Cassettes are mailed by First Class mail, on or about the 20th of the month. For information, subscriptions, renewals, back and sample copies: write to DX Audio Service - P. O. Box 164 - Mannsville, NY 13661-0164

AM Switch

Jerry Starr w8jv@yahoo.com
c/o WHOT Radio
4040 Simon Road
Youngstown, OH 44512-1320

Status changes in AM stations, supplied by the FCC and listeners

CALL LETTER CHANGES

	Old call		New call
740	CFPT ON	Toronto	CHWO
1050	WEIO WI	Eau Claire	WDVM
1060	WMEX MA	Natick	WBIX
1250	CHWO ON	Oakville	CJYE
1320	WJYT MA	Attleboro	WARL
1460	KDMI IA	Des Moines	KXNO

KRTH

AM 930  101 FM

5901 VENICE BOULEVARD
LOS ANGELES, CALIFORNIA 9003-

APPLICATIONS / GRANTS FOR NEW STATIONS

None

APPLICATIONS FROM EXISTING FACILITIES

940	CJJB BC	Vernon: to 107.5 FM
1430	KLO UT	Ogden: modify CP to show 10000/5000 U4 (see below)
1440	KTNO TX	Denton: 12000/370 U4
1500	WGTT AL	Alabaster: 2300 D1
1520	WCHE PA	West Chester: 1000 (500 CH) D1
1560	KILE TX	Bellaire: modify CP to show 50000/1000 U4
1570	KBJT AR	Fordyce: 780/8 U1

GRANTS TO EXISTING FACILITIES

620	WJWR NJ	Jersey City: relocate transmitter, change city of license back to Newark, NJ
1090	WILD MA	Boston: grant shown last week includes transmitter relocation
1340	KXEO MO	Mexico: 960/960 U1, relocate transmitter
1430	KLO UT	Ogden: 10000/5000 U4

OTHERNESS

1000	CFPL PQ	Rimouski: left the air for good 1/1/01; has moved to 102.9 FM
1430	KQLL OK	Tulsa: station has been monitored locally IDing as "KTBZ" although the FCC has not indicated any call change and records show this call assigned to an FM station in Lake Jackson, TX. We'll keep an eye on this one.
1610	KALT TX	Atlanta: new station is ON THE AIR

THANKS: Al Merriman, Bill Hale, Ed Krejny, Bruce Winkleman, Olle Alm, Shawn Axelrod, Les Johnson and MSJ

MILESTONE: This marks the 500th edition of AM Switch I've edited. It certainly doesn't seem like that many. (Congrats, Jerry. Buffalo gonna let you do another 500? -pls.)
73 and Good DX, Jerry Starr & Buffalo K. Foonman

Jerry & BKF

The NRC AM Radio Log, 21st Edition, including cross-referenced listings from 530-1700 khz., is compiled from both listeners' reports and official sources, making it the most accurate listing of U. S. and Canadian AM stations available. Unbound, three-hole punched for standard binders. Still only \$16.95 to U. S. and Canadian members; \$22.95 to U. S. and Canadian non-NRC members. Airmail to members: Latin America, \$24.00; Europe, \$25.00; rest of the world: \$28.00. Order from: NRC Publications - Box 164 - Mannsville, NY 13661 (NY residents, please add sales tax).



Domestic DX Digest

West: **Bill Hale** phantom 2@eaze.net

6124 Roaring Springs Drive - North Richland Hills, TX 76180-5552

East: **Michael Shaw** mshaw002@tampabay.rr.com

455 Alt. 19 S., Apt. 176 - Palm Harbor, FL 34683-5931

(Division line is
between East and
Central time zones)

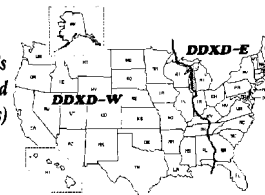

DX Catches in the U. S. and Canada, with 24-hr. ELT

DDXD-West

MEDIUM WAVE RAMBLINGS

- Lester speaks: "I can't determine if DX conditions are so much better this year or maybe it's the new -2010 (or both). Next year maybe a phasing unit?!! Can you say MFJ? This club is fantastic!!"; The saga of the season (so far), as related by **Shawn**: "Well we made it there and back but just barely. Wayne and I took advantage of warmer (only -10) weather to go to the DX site. We were greeted by an unplowed road that I must admit the Ford Taurus handled well for the quarter mile it had to go through. The bottom of the car is clean now! After unloading the equipment and loading up one toboggan we started off all together to confident. That stopped when we got to the open field. The snow was in many place knee deep and even the toboggan sank in the soft spots. With 100 lbs of stuff on it we took over half an hour to make the 1200 foot distance. We both pushed or pulled the load across the field and 50 paces was it before a rest was needed. We rested at the DX bus for 15 minutes before going back for more. After walking back to get more things like 2-50 lb batteries to power the radios I got a great idea. Went to the next farm where the young guys were playing on their snow machines. They were more than pleased to come play in our field for 5 minutes to cut a path to the DX bus. Well talk about better. The next trip was in 10 minutes and we did not sweat off 5 lbs each. Getting too old for this. Trust my in Canada DXing is not for the unfit. The good thing was we had put out antennas in late November so all we had to do was set up the radios and listen once we finished the treks. Another trip with the toboggans with the 300 lbs of wood for this season's DX'ing made sure we were staying for the night. After all that we were going to DX or pass out. As you see the DX was good with a new one from Norway on Longwave and some new domestic DX. Conditions were poorer than usual with no Mexicans heard. Also no TA or TP hets on MW. Oh well we have fun and by the way slept really well that night. Hey it just a hobby but what a hobby!!!!
- Lotsa Special Station Stuff this time around. Let's get to it!

KARV

REPORTERS

- FA-ID** Frank Aden, N7SOK Boise FRG7 with 4 foot Box loop & Radio Shack modified TRF <N7sok@aol.com>
- AB-CA** Art Blair Folsom NRD-515 & Kiwa loop <blairs@calweb.com>
- RD-IA** Rick Dau Iowa City Sony ICF-2010 + Quantum loop antenna <<rdu36@yahoo.com>
- PG-CO** Patrick Griffith Westminster Drake R-8 + Palomar loop or Car radio in '96 Ford Bronco with 31 inch whip in motion in Westminster <AM-DXer@webtv.net>
- GJ-CA** Gary Jackson Sacramento FRG-8800 + Kiwa Loop
- DKK-CA** Don Kaskey San Francisco Drake R-8A + Kiwa Loop <kaskey@jps.net>
- LJK-IL** Lester Kleidon Countryside ICF-2010, DX392-CS, Superadio II, Superadio III, various car and truck radios, + Ameco Model TPA tunable pre-amp and antenna, Select-A-Tenna, Radio Shack Loop
- CR-IL** Christos Rigas Wood Dale Kenwood R-2000 + Kowalski Loop <RigasC@email.msn.com>
- JJR-WI** John J. Rieger South Milwaukee Icom IC-R75, Kiwa loop or GE Superadio III with Terk AM 1000 loop <johnrieger@webtv.net>
- JR-OK** John Reed Ponca City SAIT MR1411 with 100' wire, homebrew balanced ferrite loop, MFJ phaser <jreed@ponca.net>
- JR-CA** Jim Renfrew (Byron, NY) visiting San Diego Drake R-8, Radio West Loop <renfrew@localnet.com>
- MS-MB** Morris Sorensen Winnipeg Drake R8* with McKay-Dymek loop or Grundig YB-400 with internal antenna <SMosor@aol.com>
- PT-WA** Pete Taylor Tacoma Sony ICF 2010, Kiwa air core loop <taytac@worldnet.att.net>

VALDX-MB **Shawn Axelrod and Wayne McRae Valhalla Beach DX Site** 2-ICOM ICR-70 + 6 Beverages going S, E and W; MFJ 1026 Phasing Unit <saxelrod@mb.sympatico.ca>
 BW-OK **Bruce Winkelman, AA5CO Tulsa** <bdwink@home.com>
 JW-CO **John Wilkins Wheat Ridge** Drake R-8, 4-foot box loop <peakbagger3@juno.com>
 Ed.-TX **Editor North Richland Hills**
 SA-MB **Shawn Axelrod Winnipeg** Icom ICR-70 & Drake R8 + 4 Foot Unamplified Box Loop/Quantum Loop, 145' outdoor wire, 100' indoor wire, MFJ 1026 Phasing Unit <saxelrod@mb.sympatico.ca>
 KR-AZ **Kevin Redding Mesa** Optimus 12-604A <lwdxer@juno.com>

STATION NEWS & NOTES

1300 KUBL CO **Colorado Springs - 1/9 2023** - New call and format; now old C&W, with slogans *The Bull* and *Classic Country* and variations thereof. Legal ID at 2059:55 as *You're tied to The Bull for Classic Country favorites. Ram 'em hard - KUBL-AM Colorado Springs*, then more music. Generally fair, with fading and QRM. Ex: KTWK, ex: NOS. This is undoubtedly my unID of 12/26, which I heard as *The Bold 1300*. (JW-CO)

1300 KAKC OK **Tulsa - 1/6 1100** - Heard with new slogan of *La-Z*, ex: *La-Bonita*. Still all SS programming. *La-Z* pronounced *La-Zeh-Tuh*. Since my SS knowledge is very marginal and I don't listen to the station regularly, not sure if slogan change means a programming change. Checked this out since the local newspaper had article about Clear Channel buying and remodeling a building to consolidate local operations of six radio stations and two TV stations. The article listed local stations affected and it mentioned 1430 as KTBZ and 1300 as *La Z*. (BW-OK)

1300 CJME(p) SK **Regina - 1/9 1948** - Heard with program *Sports Line*. Spots for Four Seasons Sports Palace and Casino Regina. Slogan: *All sports all the time, so apparently ex: News Talk*. ID not heard. (JW-CO)

1430 KTBZ OK **Tulsa - 1/6 1030** - Just heard my local 1430 with new call KTBZ, ex: KQLL this morning. They remain all sports talk as *The Buzz*. (BW-OK)

1460 KXNO IA **Des Moines - 1/6 1725** - Poor signal, in a mess, with Iowa sports talk and XNO IDs. NEW! (VALDX-MB)

1460 KXNO IA **Des Moines - 1/11 0959** - Call ID, mention of *News Radio 1040 WHO*, final comment, then legal ID at 1000: *Here it comes, another great hour of X's and O's and so much more, on 1460 KXNO Des Moines*. Fox Sports Update at 1000; local spots, program note for ISU women's basketball. At 1006, into a local sports talk program. Signal starting to go downhill by now, although still in there well past 1030. Ex: KDMI. (JW-CO)

1670 KAZT CA **Redding - 12/27** - Came on today using only 1000 watts. Will power up to the full 10,000 watts in a few days. ESPN Sports. Correct address is: 3360 Alta Mesa Drive, Redding, CA 96002. (GJ-CA)

1690 KSXX CA **Roseville - Audio feed is AM receiver tuned to KLIB-1110**. Pacific Bell has yet to install a line to their transmitter. They are also having problems with their remote circuitry, forcing them stay at 1000 watts. Should be all fixed by the time you read this. (GJ-CA)

1690 KSXX CA **Roseville - 1/8 1945** - Vietnamese program with oriental vocals, ads, and chat. At 2000, an "ID" in SS for *KLIB Roseville-Sacramento, Once Diez AM*, followed by more SS announcements and phone numbers 916-456-3288 and 916-456-3324. Don't know why they would put a SS announcement in the middle of their Viet programming; legal ID in EE at 2000: *1690 KSXX Roseville-Sacramento, 1450 KOBO Yuba City-Marysville*, and back to Viet program. All alone with KDDZ off. California #101 here. Also heard, per spot checks, SS religious service Sunday morning 1/7 at 1040, and Russian at 2230 on 1/8. SS at various other times. (JW-CO)

1690 (KDDZ) CO **Arvada - 1/7 1800** - Totally off, due to transmitter failure. Did not return until Tuesday (1/9) afternoon. Logged three new ones in their absence. (JW-CO)

1690 KDDZ CO **Arvada - 1/9** - Came back on at 1739 after being dark for four days due to transmitter problems. Standard Radio Disney network ID and no local announcement noted at sign on. Sounded like very low power initially, then a few clicks and better signal at 1826. (PG-CO)

**WWWS
YOUR MONEY
1400AM**

UNIDs and UNID HELP

580 UNID ?? - 1/9 0200 - *William Tell Overture*. Not CKUA, per station. Possibly on a CKXR commercial. I also heard fugues 1/8 2031, which probably WAS CKUA. (PT-WA)

620 UNID ?? - 12/16 2245-2350 - Usual mix of heavy rock oldies. Never before heard on 620. CKCK?? (LJK-IL)

940 UNID ?? - 1/7 - With ESPN Sports at 0145 in KWRU null. Could be either KXTK with 5 kW or KICE with 60 watts? (DKK-CA)

1190 KXKS? ?? - 12/14 2300-0200 - SS music, very weak. *La Super Equis* heard. Could it be?? Or Mexico? (LJK-IL) [The AM Log says they use that slogan - Ed.]

1190 UNID ?? - 1/6 1800 - Weak partial ID as 95.5 FM into ABC news. (VALDX-MB)

1190 UNID ?? - 1/6 1806 - Poor signal, with CNN Headline News. (VALDX-MB)

1290 UNID ?? - 1/6 2315 - BBD/NOS music in CFST null on East wire. (VALDX-MB)

1480 KRXR ID **Gooding - 1/7 0950** - Spanish talk and Mexican music. This is my old unID. Finally got ID on the hour. (VALDX-MB)

1610 UNID - 1/6 1900 - Hockey game being called. Don't think it was KALT. (VALDX-MB)

1690 UNID ?? - 1/5 2030 - Presumed KSXX with very good signal in unID oriental language. Local KDDZ off at the time. No IDs heard. Faded under noise by ToH. (PG-CO)

1700 UNID ?? - 1/9 0200-0300 - Three stations noted mixing, barely above the HNL slush. News, sports and Spanish were the formats. Likely Des Moines and the two Texans, but no ID heard. (DKK-CA)

KLUC

3 IN A ROW

DX AND EQUIPMENT TESTS

710 KNUS+ CO **Denver - 1/7 0200-0300** - Heard under KIRO with tones, code IDs and marching music. (FA-ID)

710 KNUS- CO **Denver** - Not heard due to local KIRO. (PT-WA)

990 KRKS+ CO **Denver - 1/7 0200-0300** - Heard about even with CBW, with vocal IDs, code IDs and marching music. (FA-ID)

990 KRKS+ CO **Denver** - Deep fades, an XE and lots of CBW and KOMO slop, but the marches, tones, CW and voice IDs made it 1/7 before the 0230 power drop. (PT-WA)

990 KRKS+ CO **Denver - 1/7 0216** - Poor, in CBW null and WMVP splash, with test tones, code IDs and march music. The KNUS AM 710 test running in // with this test and the KBJD AM 1650 test not heard due to too much WGN 720, which is only 5 miles from my location. (CR-IL)

990 KRKS+ CO **Denver - 1/7 0210** - Fair, with march music, a KRKS, *Denver* ID, and code IDs. (RD-IA)

1650 KBJD+ CO **Denver - 1/7 0200** - Fair, with test tones, code IDs, march music and voice IDs. (CR-IL)

1650 KBJD+ CO **Denver - 1/7 0200-3000** - Heard with almost local signal, with vocal IDs, code IDs and marching music. (FA-ID)

1650 KBJD CO **Denver - 1/7 0200-0300** - Eminently readable throughout, with not a lot of difference the second half hour. KFOX looped; KDNZ's CBS News sounder at 0300. Clear sailing (thanks Pat Griffith). (PT-WA)

1650 KBJD+ CO **Denver - 1/7 0202** - Good, with code IDs, a 1650 KBJD, *The Beat* ID, and test tones. (RD-IA)

1650 KBJD+ CO **Denver - 1/7 0227-30** - Cutting thru KFOX, with March music and Morse Code. Didn't seem to be any stronger the first half hour than any other night when they are always in there with KFOX. (DKK-CA)

TIS & OTHER STUFF

530 TIS CA **Los Angeles - 12/31 0418** - LAX information. (JR-CA)

870 WTRH840 CO **Denver - 1/9 1915** - Colorado DoT station; new here just within past few days. Repeating 10-second ID message with no actual traffic or other information. It's just there clogging yet another frequency in the Denver area. At least it's a new one, for Colorado #103. (JW-CO)

1200 UNID ?? - 1/1 1500 - TIS/HAR heard weakly. Couldn't find anything in Bill Harms' Log. (GJ-CA)

1610 UNID ?? - 1/7 0645 - Talk about Chippewa Park. (VALDX-MB)

1610 UNID ?? - 1/7 0700 - Talk about waterfalls and trails in Minnesota. (VALDX-MB)

- 1610 UNID ?? - 1/7 0810 - Talk about *Welcome to Wisconsin* by lady. (VALDX-MB)
 1670 WNE268 CA Sacramento - 12/31 - Still knocking out KAZT, and I'm 15-20 miles from transmitter. By middle of January, California will have six X-Band stations. Too many, as it cuts down on hearing other X-Banders. (GJ-CA)

WVVM
 AM 630
 The Power Voice of Wabanc

MIDNIGHT TO MIDNIGHT ELT

- 550 KFYR ND Bismarck - 1/6 0649 - Poor, with AdCon music with TC and *K-Fire 550* slogan. (JJR-WI)
 550 WSAU WI Wausau - 12/16 0100 - Just heard local ID into ABC-Info News. Rare here! (LJK-IL)
 570 WKYX KY Paducah - 12/17 2120-2145 - Syndicated talk, ID at 2130. Gave 444- 6345 news phone number. (LJK-IL)
 570 WVMI MS Biloxi - 12/17 2130 - Heard just before WKYX ID: *News, talk and information, Gulfport, Biloxi, WVMI 570*. Only second time heard. (LJK-IL)
 580 CKXR BC Salmon Arm - 1/9 0202 - ID through KFXD and KVI splatter. Very rare. (PT-WA)
 600 WREC TN Memphis - 12/31 0555-0605 - Fair, with ID at ToH in between *Coast-to-Coast AM with Barbara Simpson*. ID: *Making the Mid-South a better place - News Talk 600, WREC* and into ABC News. Rare here. (LJK-IL)
 600 CKAT ON North Bay - 12/17 2240-2310 - Armchair copy, lots of modern country music. At 2245 *Hot New Country CKAT*. New. Also heard 12/23 0200-0240. (LJK-IL)
 610 KDAL MN Duluth - 1/7 1739 - Fair with *Percy Sledge's When A Man Loves A Woman*, then chatter by DJ that included a KDAL ID, and a weather forecast with a mention of *downtown Duluth*. (RD-IA)
 650 WNMT MN Nashwauk - 1/7 0905 - Fair, with local weather, a mention of *WNMT studios*, then a promo for program called *Northland Morning Magazine* weekdays at nine. (RD-IA)
 680 KKYX TX San Antonio - 12/17 2205 - *Glen Campbell's By The Time I get to Phoenix* into *Feliz Navidad* by *Jose Feliciano*. Then nice ID KKYX 680. Mixing with WJCE, CJOB and CFTR. New! (LJK-IL)
 710 CKVM PQ Ville Marie - 1/7 0214 - Fair, just under KCMO, with talk in French. Heard during an unsuccessful attempt to bag KNUS. (RD-IA)
 740 WNOP KY Newport - 12/31 0545-0550 - Heard in passing: *We may be going out, but we're going out swinging - WNOP 740*. Going silent?? (LJK-IL) [Probably powering down or signing off - Ed.]
 740 WIRJ TN Humboldt - 12/17 1715-1730 - Oldies programming with non-IDs as *Cruisin' Oldies*. Finally, a CL ID at 1730. (LJK-IL)
 840 WHAS KY Louisville - 1/1 0536 - Time and ID then into the years movies in review. (KR-AZ)
 840 CJXX AB Grande Prairie - 1/7 0903 - Fair, with Canadian national news, ad for *Rodgers AT&T Wireless*, sports, weather for Peace River country and Grande Prairie, country music. (MS-MB)
 850 KHHO WA Tacoma - 1/10 1925 - Solid, atop with local ads, e.g. *Crossroads Appliance* in Bellevue, then back to sports show. Zapped by dimmer switch turned on nearby. (DKK-CA)
 860 KPAM OR Troutdale - 1/6 0205 - With *Radio Free Oregon* slogan after news and sports. Cutting thru KTRB quite well. Also 1/10 at 1921 with local-regional sports atop KTRB. ID at 1924: *AM 860-Radio Free Oregon*. Solid, atop at 1937. (DKK-CA)
 860 KONO TX San Antonio - 1/9 1855 - *State Farm* and other ads. Legal ID at 1857:40 *KONO-FM [city]*, *KONO-AM San Antonio*, another ad, *kono* slogan, then song *Georgy Girl*. Briefly fair. New here; Texas #155. (JW-CO) [I believe that city the FM is licensed to is Helotes, pronounced hel-o'-tis - Ed.]
 870 KRLA CA Pasadena - 1/10 0105 - With ID after news: *The New KRLA*, then into a talk show. Heavy QRM at time. 1/11 0333 atop with *Newstalk 870, The New KRLA* ID. (DKK-CA)
 870 WWL LA New Orleans - 1/1 0545 - Playing a bluegrass song then ID and into truckers program. (KR-AZ)
 870 WWL LA New Orleans - 1/10 0105 - While looking for KRLA, I heard WWL ID way down in the hash. (DKK-CA)
 870 KLSQ NV Laughlin - 12/31 0659 - *This is KLSQ Laughlin-Las Vegas* ID then into song

- 880 KRVN NE Lexington - 12/17 2215-2235 - Usual C&W fare, mixing with another C&W station! CL ID at 2230. (LJK-IL)
 880 WMDB TN Nashville - 1/6 0842 - Poor, with WCBS nulled. Calls heard. (JJR-WI)
 880 CKLQ MB Brandon - 12/17 2215-2300 - C&W. Thought to be KRVN, but turned out to be this guy. Various CKLQ and Q *Country* IDs. Rare. (LJK-IL)
 890 WLS IL Chicago - 1/5 2010 - Booming in with no fades and near local quality signal from 907 miles away on my car radio while commuting. Local 890 TIS at Coors Field barely audible underneath. Talk show with female announcer reporting on a blind man who obtained a concealed weapons permit in North Dakota after proving his proficiency on the range! (PG-CO)
 920 KSHO OR Lebanon - 1/10 0132 - With ID during local ads (for Albany). *KGAL-KSHO* nicely atop, which is unusual due to normal horrid KNEW-CNET splash from 910. (DKK-CA)
 920 WOKY WI Milwaukee - 1/10 0825 - Fair, in WSUI splash, with *WOKY* ID in promo. (RD-IA)
 940 KICE OR Bend - 1/10 1943 - With ESPN Sports, nulled in over KWRU. Was in for 10-15 minutes, still on day power. (DKK-CA)
 950 KJR WA Seattle - 12/31 1007 - *Sports Radio 9-50* slogan, in KAH1 partial null. (AB-CA)
 970 KNFX MN Austin - 12/30 0825 - With *KNFX* call ID. (AB-CA)
 950 WWJ MI Detroit - 1/6 2153 - Fair, with *Detroit Pistons* basketball *vs. San Antonio*. Heard mentions of *Pistons* players *Mateen Cleaves, Jerry Stackhouse*, and *Eric Montross* in play-by-play. Just to make sure I had WWJ and not a Spurs affiliate on 950, I double-checked with WOAI's broadcast, and the two were definitely on separate networks. KPRC had a *Rockets* game going at the same time. (RD-IA)
 1010 CFRB ON Toronto - 12/31 0800 - Call ID, news and weather. (JR-OK)
 1050 WTKA MI Ann Arbor - 1/12 0810 - Poor, but clear, with calls. In WLIP null. Sports. (JJR-WI)
 1060 WRHL IL Rochelle - 12/30 2130 - Call ID on fade-in, then lost. New here. (JR-OK)
 1070 KNX CA Los Angeles - 12/16 0220-0235 - *KNX News time: 11:35*, heard in between new stories. Rare here! (LJK-IL)
 1080 KYMN MN Northfield - 1/12 0805 - Poor, with end of NBC News into local news. Three Northfield mentions. (JJR-WI)
 1120 KPNW OR Eugene - 12/16 0200-0430 - After listening for two hours worth of barely audible talk radio and two hours of overly audible boring KMOX, finally heard KPNW ID at about 0330. New! KNX, CKNW also in tonight! (LJK-IL)
 1120 KJSA TX Mineral Wells - 1/3 0731 - Good, almost even with KMOX at times, with a *Radio Ranch* ID and area news with mentions of *the state capitol in Austin and Weatherford*. *Lee Freshwater's* web site says KJSA is only 250 watts, but it sure seemed much stronger than that. (RD-IA) [250 watts is correct - Ed.]
 1130 WISN WI Milwaukee - 1/7 0833 - Fair, with ad for local Internet provider giving 414 area code, into syndicated talk show. (MS-MB)
 1130 CKWX BC Vancouver - 12/16 0300-0600 - Poor signal, in and out with usual news stories, with many IDs. Sounded like *Bloomberg News?* Way under WBBR/WISN/WDFN/others. (LJK-IL) [Maybe *Broadcast News*, but I doubt they're "Broadcast News" - Ed.]
 1140 CHRAB AB High River - 12/14 2300-0030 - C&W, totally trashing usual pest, WRVA. Using non-ID: *Country Radio for Southern Alberta*. Rare. (LJK-IL)
 1160 KENS TX San Antonio - 1/1 0850 - And the Dave Ramsey Show. (KR-AZ)
 1180 KOIL NE Bellevue - 12/16 0300 - 1180 KOIL ID heard just before news on the hour. Rare here. (LJK-IL)
 1190 CFSL SK Weyburn - 1/6 0058 - Fair, in WOWO null, with country music, news from *Broadcast News*, sports. Then *Yesterday and today's hits on AM 1190 country*. Heard several times before, but for some reason they weren't in my log! (MS-MB)
 1200 WCHB MI Taylor - 1/7 0745 - Fair signal, with local bank ads, Gospel music, and WCHB ID. New!! (VALDX-MB)
 1210 WDAO OH Dayton - 1/12 0755 - Fair, alone and dominating, with traffic... on AM 1210 WDAO. (JJR-WI)
 1210 KGYN OK Guymon - 12/24 1855-1900 - Totally trashing WPHT with C&W music, then

- ID: *We're here for you. We're your radio station, KGYN, then more C&W music. (LJK-IL)*
- 1220 WEZU MN Stillwater - 1/7 0859 - Good, with ID: *This is WEZU, AM 1220, Stillwater. (RD-IA)*
- 1240 KWIK ID Pocatello - 1/5 0000 - Showed up with *News Leader* slogan and ID. I was subsequently hoping for a deep easterly opening but other than a very strong CBX, nothing else was different. New. (PT-WA)
- 1260 KTTS MO Springfield - 1/9 1801 - Traffic, weather, area news with *Nancy Simpson*, spot for *Systematic*. Back to *Classic Country* music at 1805. Fair signal. Not heard since three years ago. (JW-CO)
- 1290 KIVY TX Crockett - 1/10 2100 - Call ID only heard during quick fade-in. New here. (JR-OK)
- 1290 KOWB WY Laramie - 1/9 0757 - With partial ID: . . . here on KOWB. (AB-CA)
- 1300 WSJX IN Terre Haute - 1/7 0659 - Fair, with ID: *You're listening to WSDX AM 1130, Brazil, WSJX AM 1300, Terre Haute, the sports voice of the Wabash . . . (RD-IA)*
- 1300 WNQM TN Nashville - 12/25 0830 - Religious talk, call ID. New here. (JR-OK)
- 1340 KRLV NV Las Vegas - 1/9 2002 - Surfaced for 15 seconds for call ID; soon gone. (DKK-CA)
- 1360 KPXQ AZ Glendale - 1/9 1920 - With call ID by woman, after local news given by her and male counterpart from 1900-1915. Was buried in QRM until surfaced at 1920 with ID. Spent a lot of time on 1360 trying to get this guy. (DKK-CA)
- 1410 KCAL CA Redlands - 1/8 1955 - Atop, with ID in Spanish. Not that unusual, but I haven't heard them in some time. (DKK-CA)
- 1410 WING OH Dayton - 12/13 2022 - Good, with *Ohio State* basketball and an *AM 1410*, WING ID during a commercial break. (RD-IA)
- 1440 CKJR AB Wetaskiwin - 1/8 2006 - In nicely, taking 800# calls from listeners responding to *Who would you like to date?* Couldn't get an ID til 1/9 2300, as in *KJR . . . CKJR Wetaskiwin . . .* Some KODL religion, but no KMED or KVON. (PT-WA)
- 1450 WATZ MI Alpena - 1/8 2228 - Fair, out of mess, with calls. Nice and clear and NEW! (JJR-WI)
- 1450 KOKO MO Warrensburg - 1/6 0820 - Good, with ad for *Warrensburg Wholesale Carpet*, an *AM 1450*, *Ko-Ko* ID, and local weather. (RD-IA)
- 1450 WDLB WI Marshfield - 1/5 2128 - Fair, with calls surfacing briefly in mess, then back to mess. (JJR-WI)
- 1470 KLBP MN Brooklyn Park - 1/7 0937 - Fair, with nostalgic music (mostly 1950s stuff), ID, mention of Twin Cities, announcement of upcoming broadcast of service from Mt. Olivet Lutheran Church. (MS-MB)
- 1470 KITO OK Vinita - 12/17 0914 - Fair, with *KITO* ID between country songs. (RD-IA)
- 1490 KDRS AR Paragould - 1/1 2359 - Weak, with ID as 1490 KDRS, Paragould. (RD-IA)
- 1500 WPMB IL Vandalia - 1/7 0804 - Fair, with *WPMB-WKRV* ID, ad for a local bank, then into what sounded like southern gospel music. (RD-IA)
- 1530 WLSP MI Lapeer - 1/6 1700 - Sign-off. Fair, mentioning Lapeer and *All-sports AM 1530 WLSP*. (MS-MB)
- 1530 KSMM MN Shakopee - 1/7 0955 - Fair, ending service from St. John's Lutheran Church in Chaska(?), Minnesota. (MS-MB)
- 1560 KIQS CA Willows - 1/10 1951 - Poor I'll KIQS slew the mighty in-line KNZR in a small window (KZIZ off 1945, KIQS off 2015) long enough for ads, *Sinatra* and ID 1/10 1951. New and long sought. (PT-WA)
- 1590 KUNX CA Ventura - 1/6 0058 - With call ID in Spanish after many Radio Unica slogans. Was riding atop KLIV at time. Is a regular but first time IDed this call. (DKK-CA)
- 1600 KATZ MO St. Louis - 12/31 1749 - Good, with *Gospel 1600* ID and DJs taking calls at 969-1600. Some checking of the St. Louis area yellow pages turned up that number as KATZ's in-studio line. (RD-IA)
- 1600 WRPN WI Ripon - 1/8 1658 - Fair, with talk show, ID as *The place to go when you need to know, WRPN Ripon . . .* into local weather and news. (MS-MB)
- 1610 KALT TX Atlanta - 12/31 0057 - Good, with *Dreamland* program into station break and ID that sounded



- like 1610, *KALT, Atlanta-Texarkana . . . believe it. (RD-IA)*
- 1620 KBLI ID Blackfoot - 12/26 2300 - ESPN feed; nice ID on the hour. (JR-CA)
- 1620 KBLI ID Blackfoot - 1/4 0300 - With quickie ID amid ESPN stuff. To hear this I have to null local KYIZ and dig it out from under KSMH. Of interest: ESPN Orange Bowl ID openings were at almost exactly 2200 and 2300. New. (PT-WA)
- 1620 WHLY IN South Bend - 12/12 2214 - Fair, under WTAW, with . . . *WHLY, Radio Hollywood* ID and satellite nostalgia music. Heard during one of those rare times when splatter from KCJJ is at a minimum. (RD-IA)
- 1630 WRDW GA Augusta - 1/7 0159 - Fair, in KCJJ null, with 16-30 *WRDW, a Beasley Broadcast- ing Station* ID. ABC News at 0200. (CR-IL)
- 1630 KCJJ IA Iowa City - 1/9 0239 - Emerged thru slush with promos, ads for merchants in Iowa City, then into light rock music. (DKK-CA)
- 1640 WKSH WI Sussex - 1/3 0210-0301 - WTDY was giving KAZT a hemorrhage, so I dropped in here. KPBC goes off at 0100, usually leaving a strong KDIA. However, only KDIA's OC was on, making for a nice cushion. Contemporary and choral Christian music, scripture readings, low key fund raising announcements and bare SRN news at 0255 (no open or close). Seemed to ID as *Milwaukeee* rather than Sussex. Fluttery, but at good level. New. (PT-WA)
- 1650 KFOX CA Torrance - 12/29 0300 - EE ID in break during Korean programs. (JR-CA)
- 1650 KBJD CO Denver - 12/31 0255 - *The Beat* Christian music program. Calls heard at 0300, in KFOX null. (JR-CA)
- 1650 WHKT VA Portsmouth - 1/6 0600 - Poor, with NOS and ID in KCNZ null. NEW! (JJR-WI)
- 1660 KRZX TX Waco - 12/28 0745 - Local news and call ID. New here. (JR-OK)
- 1670 "KNRO" CA Redding - 12/27 0010 - Sports, with *KNRO 600* ID. (JR-CA)
- 1680 WTIR FL Winter Garden - 12/22 2010 - Fair, with info on airline flights, then a *WTIR* ID. Third catch from the Sunshine State here since starting the new logbook. (RD-IA)
- 1680 WTIR FL Winter Garden - 12/28 0735 - Information radio with weather. New here, for first Florida logging. (JR-OK)
- 1680 WTIR FL Winter Garden - 1/8 0720 - Call letter ID by gal, then scraps of audio with apparent TIS-like info. Very poor, but at least the ID came through. A new one here, and only 5th Florida station here in 20 years! (JW-CO)
- 1680 WTIR FL Winter Garden - 1/9 0232 - With travelers info, weather etc. Noted under WJNZ until 0300. 1/11 0308 noted atop and alone with nice signal giving travelers info, weather for Orlando at 0311, Florida weather at 0319 followed by *WTIR Weather Center* ID. Ads and spots followed. (DKK-CA)
- 1680 WJNZ MI Ada - 1/9 0215 - Noted with decent signal atop both WTIR and WTTM, with a rap song. More UC music followed with much patter between songs. 1680 *Jams* at 0236, stating they play 'rap, hip-hop and r&b' music. None of these stations had made it here above my horrid HNL until 1/9 when all three were in nicely. (DKK-CA) [Okay, I'll bite. What's this "HNL" - Ed.]
- 1680 WTTM NJ Princeton - 12/22 2101 - Weak, with *Penn State* basketball, with *ESPN* and *WTTM* heard during a 10-second network break for station identification. (RD-IA)
- 1680 WTTM NJ Princeton - 1/9 0245 - Briefly atop WJNZ/WTIR, with sports news. All three stations easily separated. (DKK-CA)
- 1690 KSXX CA Roseville - 12/27 0200 - ID noted in passing. (JR-CA)
- 1690 KSXX CA Roseville - 1/6 0202 - Faded up just long enough for ID: 1690, *KSXX, Roseville-Sacramento* then back into the noise. (PG-CO)
- 1690 KSXX CA Roseville - 1/6 1950 - Heard with woman in Russian, then changed to Spanish on the hour. No sign of usual Disney pest all night. NEW!! (VALDX-MB)
- 1690 KDDZ CO Arvada - 1/1 0400 - Fair, with Radio Disney programming and a legal ID. First catch of the new millennium, but I understand it was off the air for a few days in early January. (RD-IA)
- 1700t KTBK TX Sherman - 12/31 0400 - *Sports Doc-*tor call-in show, 914 area code phone number in ad. (JR-CA)

AK Radio
KORD-KZZK

GRAVEYARD DX UPDATE

indicates record held from Alaska or Hawaii

* indicates record held by DXer from North America (excluding Alaska)

1340 kHz:

WFSH FL Valparaiso Steve Kennedy Coal Township, PA Miles 905

Totals:	1230	1240	1340	1400	1450	1490	Total
Steve Kennedy Coal Township, PA	54	45	69	62	53	59	342

DDXD-East

It's another long column, but with it, we can at least put a wrap to the CHWO suspense (see below). Thanks for the many kind letters and e-mails regarding the column. I really appreciate your support and encouragement. On with the show! (Wish Michael "good health", too; he typed this one up whilst "under the weather" -pls.)

STATION NEWS

- 670 WHRP VA **Claremore** - 01/07 1700 - Good over/under WIEZ with GOS music, ID at top of hour "This is the Word in Praise, Praise 670 AM, WHRP, Claremont, Norfolk, Hampton Roads, Virginia", then back to GOS. New calls and slogan; ex-WRJR, "Rejoice Radio". (JF-ON)
- 740 CHWO ON **Oakville** - 01/08 - Began regular operations. The ODXA club is their QSL Manager from this date. Details on the ODXA website <www.odxa.on.ca>. (AR-ON)
 - + - Began regular programs today, as scheduled. Official sign-on was at 0740, with a speech by CHWO's president/CEO Michael Caine: "The switch I have just thrown marks an end and a beginning...today we launch a radio station like no other on the AM or FM dial..." They're running // 1250 for today and probably for a few more months. The REL format CJYE on 1250 isn't happening just yet. Where's the promo campaign? Here in Toronto I have not yet seen a single outdoor ad, bus shelter, subway or transit vehicle ad, or print media ad for "Prime Time 740". Unless you're a DXer or a regular CHWO-1250 listener, you wouldn't even know that there is a new station in this market. (MB-ON)
 - + - 01/08 - Began regular broadcasts. Official sign-on was at 0740. // 1250 for now. (MKB-ON)
- 920 WTCW KY **Whitesburg** - 12/30 2258 - Stays on often with high power at night; "WTCW" mentions. (JK-VA)
- CKNX ON **Wingham** - 12/30 2259 - Also stays on nights at high power. In strong at this time with "Now, more of the best country music on Country 9-20 CKNX". (JK-VA)
- 1070 WKMB NJ **Stirling** - 12/30 1415 - Semi-local daytime station leaves the air early because host has to shovel his car out of the parking lot! Station is picked up here in cold weather; signal is poor when weather gets warm. (MC-NJ2)
- 1250 CHWO ON **Oakville** - 01/08 - The new REL format CJYE hasn't appeared yet. The usual nostalgia format, // 740, with "Prime Time 740" IDs. But for how long will the 740/1250 simulcast continue? (MKB-ON)
- 1310 WDXD MI **Dearborn** - 01/03 1900 - Good with WIBA with Fox Sports Network call-in show; ID as "The X, WDXD, Dearborn". Ex-WYUR. (JF-ON)
- 1460 KXNO IA **Des Moines** - 01/06 2240-2255 - Good with basketball game; ID as "Our sister station is WHO with news, while we are sports. We are Des Moines' new 1460, KXNO". New calls and format; Fox Sports. Ex-KSO, KGGG; KDMI for me. (JF-ON)
- 1480 WZRCp NY **New York City** - 01/01 0958-1002 - "Sixteen-fifty, KFOF(X?) Torrance, the best quality stereo sound for the best AM Listeners" Male voice, with timber of a classical station ID. Hummmmm?? Best guess is WZRC New York which runs Korean as does KFOX as per NRC reflector chat. Checks later in the week confirm this to be a likely point of view. (DL/MD)
- 1520 WRSL KY **Stanford** - 12/24 2236 - Stays on the air most nights. In poorly, mixing with WWKB and rare KOMA, with C&W and "...Country 96.3" mentions. Does well for 500 watts! New. (JK-VA)



UNID, UNID HELP & PRESUMED

- 560 UNID - _____ - 01/07 2245-2330 - Seems to be three stations underneath/in null of local WFIL Philadelphia. One is ESPN carrying Sports Talk, another talk with show on meteor extinction of the dinosaurs, and third is gospel (not WFIL, which was carrying a spoken program of some sort). All three ID'd at the top of the hour, but their IDs all interfered, so I missed them all. Interesting channel: I'll be revisiting it till I've sorted this out. (DH-NJ)
- 620 WCAEp FL **St. Petersburg** - 12/31 2258-2302 - Lots of co-channel. 2300: "WCAE, St. Petersburg"; at 0400: "It's six twenty WCAE". New call for WSAA? (DL/MD) [but see below for another opinion of the call letters - MS]
- WDAEp FL **St. Petersburg** - 12/24 2146 - Fair, with WHEN, WRJZ and WTMJ in the mix with "Tampa Bay Lightning" sports. No more WSUN! New on this frequency. (JK-VA)
- 880 UNID - _____ - 12/21 2303 - Weak with SRN news under WCBS. Who is this? (JR-NY)
- 880 UNID - _____ - 01/05 2200+ - Local basketball game; later country music. (JR-NY)
- 1150 UNID - _____ - 01/06 1830-1845 - Underneath WDEL Wilmington; reggae show called "Island Sounds." Lost it when CKOC Hamilton faded in. (DH-NJ)
- 1270 WTSNp NH **Dover** - 01/07 1628 - Alone on east wire with UNH Wildcats Hockey, ran down long list of other college scores. Good bet for NH. (JF-ON)
- 1350 WLOUp KY **Louisville** - 12/20 1710 - "Mr. T's R&B Record Shop" ad. (JR-NY)
- 1630 UNID GA **Augusta** - Station is WAWX. It'll remain such for the next six months according to Harley Drew of WRDW/WAWX. (GHD-WV)

DX AND EQUIPMENT TESTS

- 710 KNUS CO **Denver** - 01/07 - Nothing heard. (KVJ-GA)
 - + - 01/07 0200-0300 - Not heard. (SF-TN)
- 740 CHWO ON **Toronto** - 12/20 2219 - Test broadcast of "new" station picked up very clear (and strong at times) with some fading. Station ID and information given every fifteen minutes. Songs included "White Christmas", "Let It Snow", and "If You Leave Me Now" by Chicago®. 2230 ID had "Bobby's Girl" playing underneath it! (MC-NJ2)
- 990 KRKS CO **Denver** - 01/07 - Possible tone around 0222; nothing definite or ID-able. (KVJ-GA)
 - + - 01/07 0200-0300 - Not heard. (SF-TN)
 - + - 01/07 0200-0300 - Not heard. Frequency dominated by CBW; "Legends 990" (WLGZ, Rochester, NY) in CBW null. (MKB-ON)
- 1650 KBJD CO **Denver** - 01/07 0200-0300 - Good on DX Test over and under KDNZ with code and voice IDs, 1kHz tones; march music. No sign of KNUS-710 or KRKS-990 tests. Did hear weak tone on 990, but too much CBW. (JF-ON)
 - + - 01/07 - Sat on this channel for the full hour of scheduled test, but nothing positive heard. Did hear many bits and pieces of a weak signal looping towards Colorado. At 0201 there were unusual and unreadable sound patterns which could have been Morse code. Also heard test tone of about five minutes' duration between 0202-0207, 0212-0217 and 0220-0225. Weaker tone heard 0229-0234. Also heard something similar 0240-0246, and 0257-0300; I think it was tone but it could have been a het (AR-ON)
 - + - 01/07 0200-0220 - Fair/good with many code IDs, tones; march music noted. One voice ID heard 0211. Much weaker closer to 0300. (KVJ-GA)
 - + - 01/07 0200-0300 - Tentative with long test tones frequently audible during WHKT's quieter songs, but that was all. With 10kw and just two stations to fight, I thought this would do a lot better (SF-TN)
 - + - 01/07 - Very tentative. Heard test tone at 0215, but no code IDs under usual pests KCNZ and WHKT. (MKB-ON)



LOGGINGS

- 540 WLUX NY **Islip** - 01/03 1432 - Weak with partial ID. (JD*RI1)
- WDMV MD **Pocomoke City** - 01/03 1725 - "You're listening to Salvation 540"; ID. (WM-MD)
- 550 WKRC OH **Cincinnati** - 01/04 1750 - Two talk show co-hosts talking "Can you believe

- Steely Dan is getting an award...those old guys. Hello, you're next on KRC". (RJ-NC)
- 560 **WGAI NC Elizabeth City** - 12/30 2040 - Various ads; "Your home for the Tarheels, NewsRadio 560"; ID. (WM-MD)
- WVOC SC Columbia** - 12/26 2105 - CBS Hourly News; spoken ID; weather forecast; Sears ad. (WM-MD)
- WVOF AL Dothan** - 01/04 1759 - End of sports call-in show (One-On-One Sports). Talk about new Redskins coach. "You're on the ball-560-WVOF, Dothan". (RJ-NC)
- WHYN MA Springfield** - 01/03 1153 - Paul Harvey with *The Rest of the Story*. (JD*RI1)
- WFIL PA Philadelphia** - 01/07 2317 - ID. Chorus by the Concordia Seminary Chorus. Discussion with Lutheran Minister Dr. Grimm. Call-in number 1-800-730-2727. Under and over WGAN. (PG-MA)
- 580 **WTAG MA Worcester** - 01/04 0327 - "Coast to Coast on News Talk 580 WTAG"; new. (JR-NY)
- CKPR ON Thunder Bay** - 01/04 0352 - Pop music; ID "Thunder Bay's News, Talk, and Entertainment Station CKPR"; new. (JR-NY)
- WTCM MI Traverse City** - 01/04 0406 - ID following news and weather, then back to "Coast to Coast"; new. (JR-NY)
- 600 **WICC CT Bridgeport** - 01/02 1540 - News, traffic; weather. 99 miles. (JD*RI4)
+ - 12/30 1353 - "WICC Radio Shopper" host Joan (?) discussing snow storm with weather reporter; reporter giving definition of "blizzard". At 1406 announced list of cancellations. (MC-NJ)
- 610 **WGIR NH Manchester** - 01/03 1143 - Fair over WIP. Talk about state rep who advocated violence. (JD*RI1)
- WIP PA Philadelphia** - 01/03 1151 - Female talk about Philadelphia. Spoken ID "WIP". 219 miles. (JD*RI1)
+ - 12/24 2010 - Was looking for WDAF but they were in poor tonight. Instead heard "The radio station that really is Philadelphia, Sports Radio 6-10 WIP". (JK-VA)
- 640 **KFI CA Los Angeles** - 12/05 2102 - Very poor with interference from WHLO, WGOE and WGST with "L.A." mentions and "KFI 6-40" IDs. (JK-VA)
- 660 **KSKY TX Balch Springs** - 01/03 1840 - Fair, Southern Gospel; "20 minutes now in front of the hour six o'clock; Bill Christianson on the Skywave now filling in for Gordon Griffin who is a little under the weather today". (SC-IN)
- 680 **WJCE TN Memphis** - 12/30 2218 - In mixing with WAPA with NOS and "Serving the Mid-South, WJCE 6-80". (JK-VA)
- 690 **WOKV FL Jacksonville** - 12/09 2200 - Top of hour ID "Jacksonville's official news, weather and traffic station, NewsTalk 690, WOKV, Jacksonville...Depend On It. It's ten o'clock". At 2205, weather "...Saturday Night lows near 50; Sunday high near the mid-seventies". First-time visitor here. (MC-NJ2)
- KGGF KS Coffeyville** - 12/30 2238 - Poor in heavy WLW splash with "Sports Fan Radio Network" mentions and "AM 6-90 KGGF" IDs. Rare here. (JK-VA)
- 700 **WLW OH Cincinnati** - 01/02 1503 - News with WLW ID; Fair. 700 miles. (JD*RI1)
- 720 **CHTN PI Charlotetown** - 01/03 1307 - "Good Time Oldies CHTN". Poor. 518 miles. (JD*RI3)
- WRZN FL Hernando** - 12/28 1710 - NOS music; ID. (WM-MD)
- 740 **CHWO ON Toronto** - 01/03 1907 - Strong signal with semi-local WRNR's night-time 21 watts nulled. Continuous Easy Listening music with no commercials. Missed earlier IDs, but at 1931, "We're unwrapping Canada's newest radio station for you. AM 740 is now in test broadcasting. Our gift: the finest music ever made, from the glorious big bands to Nat King Cole, to Elvis Presley, Roy Orbison, Roger Whitaker, and Barbra Streisand, premiering Monday, January 8. This is Prime Time Radio, AM 740. If you have questions or comments, please call us during office hours at CHWO Radio, Toronto. 416-544-0740. (PC-VA)
+ - 12/24 2100 - Good, with heavy interference from WNOP. "AM 7-40 is now in test broadcasting as Canada's newest radio station. Call CHWO Radio in Toronto at (416) 544-0740". (JK-VA)
- WNOP KY Newport** - 12/31 1724 - Ad for Kruger's (?) Bagels; "Real Jazz 740"; back to Cincinnati Cyclones hockey. (WM-MD)

NEWS-TALK-1250
WTAE
RADIO

- + - 12/24 2040 - Big signal running day power on Christmas Eve with Jazz music; mentions of "Cincinnati, Ohio" and "WNOP-AM, Real Jazz 7-40" IDs. (KJ-VA)
- WGSM NY Huntington** - 01/02 1544 - Traffic; "1100 WHLI" followed Frank Sinatra vocal. (JD*RI4)
- KRMG OK Tulsa** - 12/30 2030 - Dominant in Toronto null with "KRMG 7-40" mentions. KRMG originally stood for the "KeRr-McGee Oil Company. (JK-VA)
- 770 **KAAM TX Garland** - 01/03 1800 - Weak. End of news "...and at Legends 77 KAAM it's 50, I'm Bob Gaston". Using jingles; sounding very much like classic WABC. "Nathan Allen, 77 KAAM". (K Double A...M) with "Town without Pity" by Gene Pitney. (SC-IN)
- 790 **WWKY KY Louisville** - 12/31 1659 - Promo for fitness center; "TalkRadio 790"; "WKY". (WM-MD)
- WNIS VA Norfolk** - 12/26 2255 - ID, then Michael Reagan. (WM-MD)
- CIGM ON Sudbury** - 12/30 2106 - Good, with C&W and "CIGM 7-90" IDs. (JK-VA)
- WAEB PA Allentown** - 01/02 0741 - Fair. ID "WAEB, the best in talk: Dr. Laura, Rush Limbaugh, Joy Browne, Mike Gallagher, (etc.) 790 WAEB". (SC-IN)
- 810 **WYRE MD Annapolis** - 01/06 0726-0745 - (C&W) On the air at 7:30 with Star Spangled Banner, "WYRE" farm report and into C&W. "WYRE, the biggest little radio station on the bay, eight-ten AM"; ABC Net. (DL-MD)
- WHB MO Kansas City** - 12/24 2030+ - Big S9+++ signal all night with ESPN Sports, McCarthy's Auto and Summit Landscaping commercials; mentions of the Mark McGuire Foundation, and "Kansas City's Hometown Radio Station, SportsRadio 8-10, WHB, Kansas City". New on this frequency; no sign of WGY! (JK-VA)
- 830 **WEEU PA Reading** - 12/30 1735 - Listing of area snow cancellations of events; mentions of Reading. (WM-MD)
- 850 **KOA CO Denver** - 12/24 2350+ - excellent signal most of the evening with "Happy Holidays KOA Christmas Special"; "Merry Christmas from 8-50 KOA"; Christmas music; KOA musical jingles (rare), and at 0000, "This is the 50,000 watt Christmas Tree, KOA Denver". Then ABC News with Gill Fox. Also on 12/31 2100, with "This is the 50,000 watt Voice of the West, NewsRadio 8-50 KOA Denver". At 2103, "KOA, the most listened-to radio station in Colorado. Call (303) ___-8585". (JK-VA)
- 910 **WSUI IA Iowa City** - 01/03 0705 - Alone on frequency with end of NPR news, ID by woman: "It's five minutes after six o'clock at WSUI"; into state news. (MKB-ON)
- WABI ME Bangor** - 01/05 1815 - Surfaced over nasty internal (2 x 455 kHz) mixing spur with Percy Faith's "Theme from a Summer Place", ID slogan "75 years of service to eastern Maine and still growing, this is WABI". (MKB-ON)
- 920 **CKNX ON Wingham** - 12/30 1558-1602 - (C&W) Ads for "Hanover" area businesses. "X marks the spot for excellent music"; "This is Garth Brooks. You're listening to the number one country music station in mid-western Ontario. You know what I'm talking about, Country Nine-Twenty CKNX. (announcer) Country Nine Twenty CKNX". Midwestern Ontario News follows. (DLMD)
- 950 **WWJ MI Detroit** - 12/24 2249 - Strong, with "Remember, there's only one traffic survival station, WWJ NewsRadio 9-50". WWJ must have changed their transmitter set-up, as they come in stronger here in Virginia. (JK-VA)
- 960 **WTGM MD Salisbury** - 12/28 1740 - Local ads; "Froggy 99.9". (WM-MD)
- WTCH WI Shawano** - 12/22 0307 - C&W music, ID, local ads; new. (JR-NY)
- CFAC AB Calgary** - 12/22 0335 - "Nine-Sixty CFAC" ID heard in pile-up; rare. (JR-NY)
- WILT PA Mt. Pocono** - 12/22 0400 - ESPN feed, Mt. Pocono-Stroudsburg ID; new. (JR-NY)
- 990 **WZZD PA Philadelphia** - 01/07 0158-0214 - "WZZD Philadelphia"; weak in lots of co-channel. Nil on DX test from KRKS. (DLMD)
- CKGM QC Montreal** - 01/07 0158-0214 - Fades up from WZZD's music: "...radio network in London, England, from Radio France International (lists numerous international broadcast organizations)...If you would like to know more about CBC Radio Over Night, try out web page at radio.cbc.ca. Now for the next

MODERN RADIO / LOS ANGELES
KRLA
DIAL 1190 / 50,000 WATTS

- hour we present the programming of Radio France International. This is CBC Radio One." (DL/MD)
- 1020 **KDKA PA Pittsburgh** - 01/02 1545 - Traffic report. (JD*RI3)
WIBG NJ Ocean City - 01/03 1140 - REL with ID. Fair in WBZ splatter. 228 miles. (JD*RI1)
- 1050 **WEVD NY New York City** - 12/28 1735 - Call-in talk show; ID. (WM-MD)
- 1060 **WMCL IL McLeansboro** - 12/20 1659 - ID noted in brief break from WHFB just before news. (JR-NY)
- 1070 **WCSZ SC Greenville** - 12/30 1945 - High school basketball game between Greenville and Charleston; Ad for Verizon Wireless. (WM-MD)
- 1130 **KFAN MN Minneapolis** - 01/01 1653 - Fair over WBBR with Minnesota Timberwolves vs. Houston Rockets basketball game; slogan "You're listening to Wolves basketball on The Fan". QSLed as WDGY in 1979. (MKB-ON)
- 1160 **WSCR IL Chicago** - 01/02 1556 - Tom Marker; "XRT". Good with fade at top of hour. (JD*RI1)
WOBM NJ Lakewood - 01/03 1518 - NOS with mention of movie ratings. (JD*RI1)
KSL UT Salt Lake City - 01/03 0100 - Good. LDS promo, then ID "You're tuned to KSL 1160 Salt Lake City Utah. Coming up after eleven o'clock we have *When Radio Was*, the old time radio show". Then updated CBS news sounder and CBS News. (SC-IN)
- 1170 **WWVA WV Wheeling** - 01/02 1550 - Ads for Ovaltine; Robitussin Gold; weather from "Storm Team 9 meteorologist". (JD*RI1)
- 1190 **WLIB NY New York City** - 12/28 1720 - Accented woman heard with ID. (WM-MD)
WOWO IN Ft. Wayne - 01/02 1625 - Man and woman discussing their worst Christmases. Under WLIB (JD*RI1)
WLIB NY New York - 01/03 1251 - EE talk with references to NY politics. Good. (JD*RI1)
- 1230 **WXNI RI Westerly** - 01/03 1248 - Talk of Providence Police. WRNI mentioned. (JD*RI1)
- 1240 **WBUR MA West Yarmouth** - 01/03 1246 - Talk with WBUR ID. (JD*RI1)
- 1270 **WXYT MI Detroit** - 12/30 2230 - ID; "Detroit's new sports leader". (WM-MD)
- 1300 **WKCY VA Harrisonburg** - 01/07 1617 - Poor atop jumble with ID "Set your radio to the station that plays your favorite music, AM stereo 1300, WKCY". (JF-ON)
- 1320 **WGET PA Gettysburg** - 01/01 1158-1202 - Mentioned Gettysburg frequently in advertising. "...across from the Gettysburg Post Office..." CNN Net. (DL/MD)
- 1330 **WYRD SC Greenville** - 12/30 1900 - Break in talk show; "NewsRadio 1330"; // WORD. (WM-MD)
- 1360 **WWOW OH Conneaut** - 01/03 1712 - ID, Kroger ad; new. (JR-NY)
- 1370 **WALK NY Patchogue** - 01/03 1217 - "Sunrise 1370"; spoken ID "WALK". (JD*RI1)
WFEA NH Manchester - 01/03 1220 - "WFEA Satellite Forecast". (JD*RI1)
WXXI NY Rochester - 01/01 1458-1502 - "...you are listening to WXXI AM Rochester"; NPR Net. Using USB to minimize adjacent channel interference from WWLG Baltimore on 1360. (DL/MD)
- WSPD OH Toledo** - 01/05 2130-2210 - "News Radio 1370"; "Northwest Ohio weather". (DH-NJ)
- WLTC NC Gastonia** - 01/05 2130-2210 - Religious/gospel format; "Rejoice Radio"; frequent mentions of a Gastonia church. (DH-NJ)
- 1380 **WSYB VT Rutland** - 12/26 1908 - After news, ad for car service; "Vermont's sports station"; ID. (WM-MD)
- WKDM NY New York City** - 01/03 1201 - SS News. Mentions of BQE and NJ Turnpike. Nulled WNRI. (JD*RI3)
- 1390 **WRIV NY Riverhead** - 01/03 1214 - Slow music with "1390 WRIV". (JD*RI1)
- 1410 **WPOP CT Hartford** - 01/03 1912 - College basketball heard; ESPN Radio; ad for law firm in central Connecticut. (WM-MD)
- 1420 **WCOJ PA Coatesville** - 01/06 1458-1502 - "...Chestertown. This is fourteen-twenty WCOJ Coatesville, Westchester". Weak in co-channel with WKCW; female reading news. (DL/MD)
- WKCW VA Warrenton** - 01/06 1458-1502 - (C&W) Faded up just after WCOJ ID. Reads local news before the hour. At 1500:30 "Local news at the top of every hour...on fourteen-twenty WKCW, weather...fourteen twenty WKCW...". (DL/MD)



AM 850 kts 5,000 watts Day Night
 FM 103.7 mcs 27 kw ERP Stereo Multiplex
PO Box 14244, New York, New York 10024

- WCED PA DuBois** - 01/06 1958-2002 - (A/C) "Make time for Paul Harvey's *Rest of the Story* weekday afternoons at four on WCED DuBois. (ABC jingle); From ABC News I'm Steve Taylor..." in the clear, practically no co-channel. (DL/MD)
- WNAV MD Annapolis** - 01/05 0858-0902 - "...only on your home town station 1430 WNAV. "News, sports, information, music and more. 1430 and WNAV Annapolis and wnav.com." Followed by CBS News. (DL/MD)
- WNSW NJ Newark** - 01/06 2058-2102 - (ETH) Slavic(?) language male in monologue. Faded down on the hour for: "WNSW, Newark, New York", monologue resumed. Checks at the top of the next two hours on 1430 were similar. At midnight into GOS. (DL/MD)
- 1440 WNSW NJ Lansdale** - 01/03 0058-0102 - "When Montgomery and Bucks County residents need to know, they rely on Info Radio fourteen-forty WNPV Lansdale. AP Network News..." (DL/MD)
- WRBP OH Warren** - 01/03 0158-0202 - (SPT) "The Voice of the Valley, fourteen-forty, WRBP Warren". "Sports Fan Radio Network". (DL/MD)
- WTHM PA Red Lion** - 01/03 0858-0902 - (REL/TLK) "Your dial is at the right spot. AM fourteen-forty WTHM, Red Lion-York, Christian Talk Radio". (DL/MD)
- WRRO OH Warren** - 12/26 1800 - Call-in talk show heard; ID // WASN; USA Network News. (WM-MD)
- 1450 WFFX MS Meridian** - 12/26 1936 - Tentative with "1450 WFF_" and SportsTalk programming. (KVJ-GA)
- WQNT SC Charleston** - 12/26 1857 - ID "WQNT, Charleston's ESPN Radio 1450". (KVJ-GA)
- 1460 WGNA NY Albany** - 01/04 0251 - With local WWVG off, heard WGNA 107.7 FM ID; new with these calls. (JR-NY)
- 1470 WBTX VA Broadway** - 01/03 1705 - Weather, ID. (WM-MD)
- 1480 WGBU MI Kentwood** - 01/01 0858-0902 - "WGBU Kentwood, WGBF Allendale, (and two more WGB_), member supported...it's nine o'clock". "...Monday on the WGBU morning show...". (DL/MD)
- WADR NY Remsen** - 01/04 1758-1802 - Various Central New York area spots with sports One-On-One promo, then a string of 3 IDs, the middle one being: "fourteen-eighty WADR", then into a fade replaced with "WZRC New York". (DL/MD)
- WZRC NY New York City** - 01/04 1758-1802 - Observed in WADR fade: "WZRC New York" followed by weak Asian language & co-channel. Subsequent 1480 checks during daytime on 01/05 indicated nearly-continuous Asian (Korean?) broadcasting with infrequent IDs on this frequency. (DL/MD)
- WABB AL Mobile** - 01/07 0104 - With Southern Miss. Golden Eagle basketball post-game show (KVJ-GA)
- WTOY VA Salem** - 01/02 1923-1943 - Urban-contemporary music, R&B oldies. "AM-1460 WTOY", PSA for donations to a local needy family. (KVJ-GA)
- 1490 WVGB SC Beaufort** - 01/04 0055 - "Your Inspirational Leader to Victory"; black gospel music. (KVJ-GA)
- WGYM NJ Pleasantville** - 01/03 1204 - "This is the SportsCenter, ESPN Radio 1490" non-id. espn1490.com mentions. 218 miles. (JD*RI1)
- WARK MD Hagerstown** - 01/02 0858-0902 - "WARK Hagerstown-Frederick"; "...it's nine o'clock; 21 degrees...oldies one oh six point nine..."; numerous Frederick ads. (DL/MD)
- 1500 KSTP MN St. Paul** - 01/06 0853 - ID as "The Talk Station, AM 1500 KSTP" into PSAs from the Ad Council, Little Brothers, and the National Fatherhood Initiative. No sign of WTOY. (MKB-ON)
- 1520 WTRI MD Brunswick** - 01/07 0855-0955 - On the hour and half hour: "WTRI, Brunswick, Washington, Baltimore". Program consisted entirely of computer generated music during period I listened. There were no voice announcements or advertising. (DL/MD)
 + - 01/03 1715 - Easy Listening music; ID. (WM-MD)
- KRHW MO Sikeston** - 12/29 0700 - ID only "This is Southeast Missouri's home for...the best...KRHW Sikeston"; into CNN News, then gone. (KVJ-GA)
- 1540 WJTT TN Jellico** - 12/29 0745 - Sign-on, into weather, church news and southern gospel music. (KVJ-GA)
- 1560 WQEW NY New York City** - 01/05 1658-1702 - (KID) "...Radio Disney, WQEW, New York City". (DL/MD)



- 1570 **WRHD NY Riverhead** – 01/02 1510 – “103.9 RCN”; strong over WPEP. (JD*RI1)
WXLN IN New Albany – 12/26 2020 – “Your home for Southern Gospel music”; spoken ID. (WM-MD)
- 1580 **KCHA IA Charles City** – 12/20 1630 – ID noted at this early hour, noted later 1800-1810 with CNN news and Gabriel Rifkin Show call-in. (JR-NY)
WTCL FL Chattahoochee – 01/01 2023 – Good signal heard with slogan “WTCL, We are your local radio station”. Numerous ads for ministry programs; also ad for The Fish House Seafood Restaurant. Previously as WSBP. (HJH-PA)
WZKY NC Albemarle – 01/06 2046 – Up fair briefly with slogan, “A Great Place to Be, 1580-WZKY”. Oldies music. Heard very weakly most evenings. (HJH-PA)
WSMO NC Camp Lejeune – 01/06 0900 – In with good signal at this time. Slogan: “NASCAR Racing, Country & Western music, A Winning Combination”. Back to “The Nashville Sound” program. Faded shortly afterwards. (HJH-PA)
WRDD PA Ebsburg – 01/06 2123 – In with oldies, weak to fair. Had ad about advertising on WNCC-950 which this simulcasts. (HJH-PA)
- 1590 **WAKR OH Akron** – 12/28 1832 – PSA; ID; promo for New Year’s Eve celebration in Akron. (WM-MD)
- 1600 **WWRL NY New York City** – 01/02 0001 – “WWTL, New York City-playing great music from great cultures”. (RJ-NC)
 + 01/03 1444 – Health Talk Today. “Right Here on WWRL” at 1459. (JD*RI1)
- 1610 **KALT TX Atlanta** – 01/01 2257-2305 – Fox Sports Radio, “Success Story” feature; ID “KALT, News-Talk Radio, AM-1610, Atlanta-Texas. Believe It!”; into SRN news, then more Fox Sports Radio. (KVJ-GA)
- 1620 **WTAW TX College Park** – 01/03 2345 – Ad for Texas A&M Basketball; “Buy tickets through TicketMaster”. Back into Michael Reagan Show. At 2355 call from someone in Texas. Another ad for Texas A&M basketball; mention of Read Arena “.it’s a slam dunk”. “Join Coach Watkins”. Mixing with WHLY. Received e-mail confirmation with QSL to follow. (PG-MA)
- 1650 **WHKT VA Portsmouth** – 01/03 1115 – NOS with mentions of Portsmouth. (JD*RI2)
- 1660 **WWRU NJ Jersey City** – 01/03 1123 – Ethnic. Good. (JD*RI3)
- 1700 **KBGG IA Des Moines** – 01/07 2340 – Discussion about new sports arena. Mention of Iowa State. Mixing with KTBK and WAFN. (PG-MA)
- 1700 **KTBK TX Sherman** – 01/08 0000 – ID. SportsCenter. Mention of espn.com and interviews coming up. ID 1310 Dallas-Ft. Worth and KTBK Sherman. Ad for Plano Office Supply and Sto2001 Financial Conference to be held at Plano Center. Mixing with KBGG and WAFN but clear and strong by 0010. (PG-MA)



Radio Station: WKSX & WKSX-FM
 700 No. East, Niagara, Buffalo, NY 14203

TIS AND MISCELLANEOUS

- 530 **HAR PA Lehigh Valley** – 01/03 0805 – Heard this one again this trip, still running taped message common to all of my local Turnpike HAR’s on 1640. No mention of 530 or any calls. This is supposed to be on 1640, with call WNRW290 per FCC info. (RJE-PA1)
- HAR PA Lehigh Valley** – 01/03 0820 – Heard with tape announcement using 530 frequency but no calls (otherwise similar text to the 1640’s). Per FCC data, this, too should be or is soon to be on 1640 also with WNRW290 calls. (RJE-PA1)
- WPNY936 PA Moosic** – 01/03 0910 – Lackawanna County Visitors Information Radio heard with lengthy taped litany of attractions, and frequent ID’s. (RJE-PA2)
- WPBG740 PA Lackawanna County** – 01/03 0935 – Another rebroadcast of NOAA Weather with occasional brief announcements using this call. Unable to determine stated location. Weak under WPNY936. (RJE-PA2)
- 1610 **HAR PA _____** – 01/03 0916 – With relay of NOAA Weather radio from the Wilkes Barre/Scranton Airport, with periodic voice-over announcements about a test of [undistinguishable] radio on 1610. No calls given. Weak mixing with WPBG740. (RJE-PA2)
- WPBG740 PA DuPont** – 01/03 0925 – Test broadcast with short taped loop “This is a test of Pennsylvania Department of Transportation Highway Advisory Radio station located at DuPont, PA” (RJE-PA2)
- 1630 **WPMQ427 PA Lehigh Valley** – 01/03 0750 – Heard with continuous loop “This is the Pennsylvania Department of transportation Highway Advisory Radio for Lehigh Valley travelers. We are conducting tests on 1630 AM station WRW833”. Signal extremely strong to 20+ miles south and 15+ miles north of I78/US22

corridor where station is located (it is not directly adjacent to I-476, hence couldn’t pinpoint). Also couldn’t determine any second transmitter, as there had been before. Announcements continue to use obsolete calls. This one should be widely heard again. (RJE-PA1)

- 1640 **WPNX700 PA Lake Harmony** – 01/03 0835 – PA Turnpike HAR heard with usual tape loop and no call ID’s. At least this one’s where it’s supposed to be, hi. (RJE-PA1)
- WPBG740 PA Dunmore** – 01/03 0910 – Test broadcast heard with brief taped announcements voiced over Wilkes Barre/Scranton NOAA Weather radio: “This is a test of the Pennsylvania Department of Transportation Highway Advisory Radio station located at Dunmore, PA, with an FCC ID of WPBG740”. Nothing listed as operational for this frequency/location, although two in Lackawanna County are pending. (RJE-PA2)
- UNID NY Rockland County** – 01/04 2318 – Rockland County Fire and Emergency Department. Discussion of family disaster plan. Phone for emergency 1-877-424-4100; gas emergency hot line 800-533-5325. Mention of Gordon Wren Jr. 364-8900. www.rockland.com. Weak but clear over WKSH. (PG-MA)

OFF THE INTERNET

ADDRESS UPDATES

- 1210 **WSBI TN Static** – Correct address is P. O. Box 160, Byrdstown, Tennessee 38549. 877/977-9724 or 606/387-6625. WSBI’s power is 930 watts. (GHD-WV)

REPORTERS

- MKB-ON Mike Brooker Toronto Panasonic RF-2200; RFB-45.
 SC-IN Steve Chappell McCordsville – Bearcat DX-1000; 3 terminated loops.
 MC-NJ Mike Clancy Jersey City – Realistic 12-614.
 MC-NJ2 Mike Clancy Jersey City – SONY ICF-7480W.
 PC-VA Perry Crabill Winchester – Drake R8; Kiwa Loop.
 GHD-WV G. Harley DeLeurere Hendricks – Address updates.
 JD*RI1 John Dunn Newport – 1993 Subaru Car Radio.
 JD*RI2 John Dunn Newport – Radio Shack DX-398.
 JD*RI3 John Dunn Newport – Radio Shack DX-399.
 JD*RI4 John Dunn Newport – Realistic DX-440.
 JD*RI5 John Dunn Newport – GE SuperRadio III with Select-A-Tenna.
 RJE-PA1 Russ Edmunds Blue Bell – Car radio & whip; various locations along I-476 (PA Turnpike NE Extension).
 RJE-PA2 Russ Edmunds Blue Bell – Car radio & whip, parked in downtown Wilkes-Barre, PA.
 JF-ON Jeff Falconer Clinton – Drake R8B; pair of 135’ terminated wires, MFJ-1026 phase box; Timewave DSP-599zx.
 SF-TN Steve Francis Alcoa – Radio Shack TRF; Select-A-Tenna.
 PG-MA Phil Greenspan Marshfield – GE SuperRadio III.
 HJH-PA Harry Hayes Wilkes-Barre – Zenith Trans-Oceanic; Kiwa Pocket Loop.
 DH-NJ Dave Hochfelder New Brunswick – SONY ICF-2010 with internal antenna.
 KVJ-GA Karl Jeter Lawrenceville – HQ-150, Sangean ATS-803A, Quantum loop; Kiwa MW loop.
 RJ-NC Russ Johnson Lexington – Sangean DT200V (Radio Shack version) and Sony 7600G; Radio Shack MW Loop.
 JK-VA Jeff Kitze Crewe-Burkeville – Panasonic RQ-V60 Walkman; SONY FD-555 AM/FM/TV barefoot.
 DL-MD David Larrabee Columbia – R8500 on loop or long wire.
 DL-MD David Larrabee Columbia – Unattended TenTec RX-320 with AMRAD LF Mod and long wire, running KF50J RX320 Controller gathering timed samples at the top of the hour.
 WM-MD William McGuire Cheverly – DX-398.
 JR-NY Jim Renfrew Byron – Drake R8, 1000’ E/W wire; Grove Antenna Tuner.
 AR-ON Andy Rugg Cornwall – HQ-180A and Quantum loop.

KTOL

AM 1280

Sunrise-Sunset Maps

Monthly maps (12) showing the average monthly sunrise/sunset times for the U. S.; customize them for your location. \$3.00 for NRC members (\$4.50, non-members). Order from NRC Publications; NY residents, add sales tax.



DX'er's Notebook

Shared tips, topics, and Internet info

It was good to see some additional discussion on this topic in recent "Musings". I'm going to start this time with a recent clarification from John Callarman, and then back into the discussion.

John Callarman <JohnCallarman@email.msn.com>: I just noticed in my long but simplified precis on publishing that appeared this fall on the reflector and in the December 25 DX'er's Notebook, I left out one transition which may make it appear I had attributed the "setback referred to in discussions about attempts to make the NRC log a private profit-making venture" to the "good people in Louisville." The setback occurred after our Louisville publishing team turned over publishing to an individual in the upper Midwest. Long-time members who know the club history look at Louisville's publishing team and the two NRC conventions it hosted as among their fondest memories. I do. I would not want anyone who came aboard later to think there was any problem questionable lines with Louisville. The LADs were good guys.

ELECTRONIC "DXNEWS"

Barry McLarnon VE3JF <bm@lynx.ve3jf.ampr.org>: "It is important to keep in mind that any EDXN would, for the foreseeable future, be an "option", not a "replacement". I think we're already seeing that many of our most computer-literate members would still prefer a paper DXN. But there are some who would prefer the electronic version. Is it enough to justify the effort and risk? Good question." The print and electronic formats each have their strengths and weaknesses. Retiring to your easy chair to peruse your newly-arrived copy of DXN sure beats staring at a CRT. It's later, when you want to use them for reference while DXing that the print formats fall short. Hmm... I think I read something about that station in DXN... was it last month, the month before, six months ago... flip, flip, flip... yawn. So much easier to have the issues on your hard drive and "grep" through them to find that call sign or frequency. Similarly for the AM Log - the print version is great for marking up, making notes, etc., but a pain for searching. For both DXN and the AM Log, I'd subscribe to both print and electronic versions if they were available. I doubt if I'm the only one who feels that way, so I expect that any reduction in numbers opting for the print versions would be offset by those opting to get both types.

Frederick R. Vobbe <fredv@nrcdxas.org>: "I think you'll find a significant number don't want to pay the \$24. They're thinking that since there is no expense for paper or postage it should be possible to offer an EDXN at considerably lower dues." Perhaps we should look at something like "All Access" does for radio users. The problem I have with web publishing is that the notion of it being electronic translates to no expense. I can speak from experience that there will be expenses to providing an EDXN, and people can not expect it for free... unless they want to do like other publications do and simply cut and paste from other web sources, sometimes without credit. "I don't think uncredited use in other publications/sites would be significantly more common than it already is. It's not all that hard to retype individual items." Except for the lazy factor. I seldom see anything printed in DXN in other lists, where it is not uncommon to have material from this list in other mail lists, and printed in publications because it's so easy to forward something of interest, cut, and paste it. "prefer a paper DXN. But there are some who would prefer the electronic version. Is it enough to justify the effort and risk? Good question." Perhaps I should also ask, what is it that DX News has that need to be on the web that is not covered in the list(s)?

Russ Edmunds <wb2bjh@nrcdxas.org>: That's an interesting question, but I think we've got two things going on here. Some are talking about some kind of E-DXN on the web, perhaps on a site, while others are talking about some kind of an e-mailed DXN. What I do know is that both aren't necessary because they are largely mutually exclusive. The issue as to what's in DXN that needs to be electronic that isn't on the lists goes back to a comment I made about the near non-use of the DXTIP list except for advance announcements of CPC tests. That's an electronic vehicle that's really not being used the way it could be for tips. So does that say anything relevant about this whole issue???

Richard Toebe <rictoebe@jps.net>: "The problem I have with web publishing is that the notion of it being electronic translates to no expense." IRCA's SDXM is not free; it costs \$10 a year. Disclosure: I subscribe to both the SDXM and hard copy DX Monitor from IRCA, which costs more than just subscribing to the hard copy. If DXN offered a SDXN, I would get both as well. We had quite a discussion about this subject in the IRCA listserv a while back, although the motivations at that time were a bit different (there was the crisis of how the bulletin would continue to be published after Ralph Sanserino ended his role as

Dave Braun dcbraun@delanet.com
863 Allabands Mill Rd.
Camden Wyoming DE 19934-2132



publisher). Many of you on this list are aware of that, so I won't go into a major rehash of the whole thing. What is the purpose of dues? To support the operations of the club, subsidized as heavily as it is by the vast efforts of unpaid volunteer labor. If theoretically 100% of the membership were online, and you could eliminate the costs of postage, printing, and accounting for funds brought in by subscription (lots of legal requirements even for non-profits), there would be a good argument for eliminating dues. But who pays for Paul's crashed hard drive, used heavily in the production of DXN? Who pays for the costs of maintaining a web presence? ISPs are known to fine customers who exceed their download limits per month, if you just maintain a web page. What about installing a server and paying for a domain name? As editor of the IRCA Slogans List since 1981, I was always allowed to ask for a reimbursement of my cash expenses, but as they were pretty low I never bothered to. We all know from experience that some DXers are stingy; every time IRCA instituted a dues increase members were lost. Even commercial websites are learning this the hard way, because this sense that the internet should be free has taken hold. Radio Digest and TheStreet.com come to mind here. So does Napster and MP3 downloads. Paul has pointed out in the IRCA listserv that NRC publications like the Log help to keep club dues to a minimum. Phil says that 40% of IRCA's members subscribe to the SDXM. How many of those subscribed because they can get the bulletin e-mailed to them for \$10 a year? There are lots of reasons why DXN should or shouldn't be online. I won't rehash them either, they've been covered pretty thoroughly over the past few days. But from a strictly financial point of view, it would be interesting to know if having the SDXM has helped or hurt IRCA's finances and membership. I don't remember seeing anything about this in DXM, and I haven't been on the Board in years. The cold reality is that the club must be solvent. That is a fact regardless of how the bulletin is distributed. DXMidAmerica is a great DXers reference, I enjoy reading it, but it's not a club. It's a labor of love by the editor/publisher, but has no legal status as far as I know. Herman Boel's European LW-MW list, downloadable as a PDF file, is a wonderful reference, better than WRTH, but it's not a club (and he asks for donations to help offset his costs). As I see it, this listserv is the equivalent of the clubhouse—a restricted clubhouse, even if no one discriminates purposely. The requirement that you have a computer and be online is the restriction. It definitely is not the formal meeting, where minutes are taken and copies sent to everyone. It is great that we see abridged summaries of what goes on here printed in DXN, this might induce non-online members to get in on this. Kevin Redding says that we should have a choice, not either/or. Choice is good. However, the financial factor cannot be overlooked as long as NRC is a constituted legal entity. Thanks for sticking with me through this lengthy posting!

Kevin Redding <ldwxer@juno.com>: "We had quite a discussion about this subject in the IRCA listserv a while back, although the motivations at that time were a bit different "Oho boy! There was way more excitement then than I care to remember. It did work out, and for the best I think. Everyone got what they wanted. Well, except for Phil who got more work. Thanks Phil. "Phil says that 40% of IRCA's members subscribe to the SDXM. How many of those subscribed because they can get the bulletin e-mailed to them for \$10 a year?" That 40% figure is amazing to me. I am very surprised that its that big. And there was 2 reasons that I went the SDXM route. The first is that it was \$10. I said before to make the cost \$15 back then maybe even 20 I can't remember but the price was part of it but the main thing is that I didn't want to have a huge stack of paper issues laying around. I figured that if I helped save a tree and keep some chemicals out of the river, then its a good thing. "But from a strictly financial point of view, it would be interesting to know if having the SDXM has helped or hurt IRCA's finances and membership." I would love to know this since I am the one that stirred the pot in the beginning. I am glad to know that it is successful in ways but I would hope that its a financial success too. "Kevin Redding says that we should have a choice, not either/or. Choice is good. However, the financial factor cannot be overlooked as long as NRC is a constituted legal entity." I did say that and do believe it completely. I also agree that we need to take in enough money to have a server or some space on a server to do it, upkeep and maintenance and probably upgrade of the machine from time to time. We don't have to make huge profits but we need to continue to take enough money in to keep the club from imploding. I say kudos to Phil and the IRCA group for the SDXM and the innovation they created. I like IRCA for the SDXM and I like NRC for their server and DXAS. DXN is OK and I enjoy it but not as much as the SDXM and DXAS. Everyone should get what they want and for that, we should expect to pay for it.

Mike Pietruk <pietruk@shellworld.net>: Kevin, With the cost of printing and postage, I would have to think that the IRCA, at year's end, has more to show for a \$10 SDXM subscription than the cost of a print one. I have to believe that much of the cost of a conventional IRCA or NRC subscription price is eaten up by those 2 items leaving only a minimal amount to the groups to cover their other costs of operation. I would think that distributing printed issues is a highly costly means of getting the material into the hands of the subscribers though, as many here have already stated, it is their preferred means. The interesting question I have for Fred is how much of the cost of producing the DXAS is absorbed by the cost of the tapes themselves, the mailers, postage and the need to supply replacement tapes. Subtracting those cost out, I would believe, might reduce DXAS costs considerably with perhaps some of that given back to subscribers as a cost reduction for those that subscribed for an Internet only

940 WADV

available edition and perhaps some of the savings kept by the club to subsidize other production costs including wear and tear on Fred's equipment. Please note, that before anyone begins screaming, I am not suggesting that the DXAS give up the tape edition. Rather, with what we have been discussing here perhaps creating an Internet only downloadable option for perhaps \$10-15 a year.

Russ Edmunds: "Everyone should get what they want and for that, we should expect to pay for it." If only a small handful, say even as many as 50, want an EDXN, then the per-individual cost would be prohibitive. There is a real-world limit on everybody getting everything they want... Somewhere, there has to be a "floor" for the number of subscribers, and then somewhere north of that there should be a number where the cost won't scare many potential subscribers off. If we had an answer to the "more work" argument, we could then try to speculate on those other numbers....

Kevin Redding: "Please note, that before anyone begins screaming, I am not suggesting that the DXAS give up the tape edition. Rather, with what we have been discussing here perhaps creating an Internet only downloadable option for perhaps \$10-15 a year." I don't care which people want, as long as its available, people will use it and since its already on the net, perhaps asking people to pay for access will not be a bad idea. Me, I will still get the tapes. What would be nice is if the BoD decided to have a reduced price net only version and the tape version. Since its on the net, only those who pay for the reduced version can access it. Perhaps those who pay full price for the tapes can also have access to the net DXAS. That is more up to Fred than anything else since it would be more work for him.

Frederick R. Vobbe: Kevin, the DXAS is on the net now, and it's FREE. If you can tolerate Real Audio, it's at <http://www.nrcdxas.org/ra>. I don't charge for it as I consider Real Audio about as good as calling a McDonald's hamburger a good cut of meat. There are people that are not bothered by it, but I can't listen to it. I get to about mid-way in Jerry's column then loose interest. Cassettes are still the way to go unless you have the bandwidth for MP3. Maybe I'll change my mind after we put WNRC-Web on the air, and Real Audio upgrades the algorithm for G2 to make it sound better.

Russ Edmunds: Given all of the discussion on this the past several days, I'm going to try to sort out, briefly, the major issues, as I see them:

- 1) Is there sufficient demand for an electronic DXN-type vehicle?
- 2) What is the 'benefit' of doing it - better timeliness? ability to e-copy items more easily? Save trees? Other?
- 3) If so, what should it be - a duplicate of DXN, or a partial duplicate containing only some things? Or something else?
- 4) Which things from DXN should it have?
- 5) Should it be like an email or on the website?
- 6) Who will do the work? What if there is added work required of the current publisher?
- 7) What about hardware/software costs to do it, if needed?
- 8) What will it cost? What would be the cost differential to produce it vs. paper?

I'm not going to pretend that I have any answers on this, in part because I really don't know what I'd like to see in it, nor do I know how much I might find it useful. Clearly there would be times where I'd like the ability to e-copy material, but given Phil's statement of how much faster it is than mail, I think I'd rather people used the DXTIP list. But Fred's right that if we don't have the right reasons, and the several of us who've said that there needs to be sufficient demand are also right, and so was whom ever it was who said that we'd need to have some better consensus on content and medium too. Right now in my mind, it's in the "nice to have" category. I'll have to think about it further and see what some of the other answers turn out to be before I'll move it to some other category....

Frederick R. Vobbe <fredv@nrcdxas.org>: "The issue as to what's in DXN that needs to be electronic that isn't on the lists goes back to a comment I made about the near non-use of the DXTIP list except for advance announcements of CPC tests. That's an electronic vehicle that's really not being used the way it could be for tips. So does that say anything relevant about this whole issue???" I think it does speak very well for the utilization of bandwidth. Let me be politically incorrect for a moment, and if I get the hair to raise up on your neck please allow me the latitude of these statements as "discussion" and not personal attack. In other words, think about what I'm going to say carefully before taking it out of context and posting an embarrassing reply. We as DXers have two strong traits. We're cheap and we love high tech. Let me address the high tech issue first. We love radios that perform well. We love to advance the technology by building better antennas and better receivers. Unlike a regular listener, we build beverage antennas, phasing units, and filters. We get angry when the outside world descends on our hobby, as in TVI, man made noise, or that %#^ splashing station which is on day facilities at night. Our opinions are strong and we're not afraid to say what is on our mind. Some folks can be exhibitionists of sorts, that is, not participating in group discussions but only posting (or submitting to DXN) when there is something to crow about. For the most part we love radio, we like to talk about it, and promote it to its highest technical form. While this is great, it does offer some problems when it comes to the Internet and web. The problem is the perception of usable information. How is it suppose to look? What form will it

WPHY 560 am

PENNSYLVANIA MEDIA ASSOCIATES, INC.
1115 Franklin Way, Lafayette Hill, PA 19343

be delivered, (web, digest, HTML, pdf)? What will be the content? How quick should it be delivered? This is a big struggle because everyone has their own "solid" opinions as to what it should be. Perhaps the biggest problem with Internet newsletters is the issue of time. That's right, time... or should I say the perception of it in relationship to our personal lives. There is not a month that goes by that some angry email will show up blasting me for not answering an email that someone sent that I didn't respond to within 2 hours. There is the mail someone sends while I'm away on business, and somehow I'm negligent in my duties with the NRC for not taking the entire studio and club database with me to reference a question that was asked. The perception is that the "send" key is like a pager, and that my prompt reply is required because it's electronic. Yes, these are rare, but they happen, but what does it have to do with this discussion? I fear that even with an electronic DXN there will be those who will still not find it acceptable because it's not instant enough. A catch today (Sunday) will be no longer useful if the person receives the EDXN on Monday, Tuesday, or beyond. Again, the expected perception of time vs. information content plays into this heavy. Will people be satisfied, or will folks be unhappy because that message that was posted at 3AM was not in the magazine that was mailed at 6AM the same morning? Then there is the format. I still feel that although some people can read PDF, HTML, and other formats, that is not the right way to go. I have a T3 here for my bandwidth, so is it acceptable for me to assume everyone else should be the same speed and I? No. Any publication should be straight ASCII text, and if you have a picture or something that you want to show, we can post it on the web server with a link to it. Now, let me address the cheap. The perception again with many on the Internet is that because it can be clicked on and emailed, that it should be better and with less cost. While it can, there is a price to pay for immediate, and quality content. Someone is paying for the connections and servers. If someone has to assemble and post a publication, that is time and money. Their time, their money in the connection. I think that if anyone is thinking of going to an electronic publication to get away from paying for a magazine, you're kidding yourself as to the quality and longevity of the publication. I have yet to see anything of quality and substance be cheap. If cheap is better, let the IRCA drop it's \$10.00 fee for the E-newsletter and all clubs should be on the web, open to the public, no dues, and not print anything on paper. That's cheap... lets see how long it's going to last. It seems to me that the NRC has two things that work well. DX News in print is great, and our lists are "the most* efficient way to transfer info (albeit they are not used to their full potential). If you have a tip, put it in the DXTIP so those of us who are in the list can get the alerts. Perhaps we should entertain the idea of a web page for submitting your loggings, which would automatically send them to the DDXD editors and post them in a special digest edition or web page. What about a putting all stories, articles, FCC news into a separate list? What about some type of comment page where you could report changes for AMS to Jerry and the rest of the group? You folks tell me what would work the best. But again, I would caution anyone from seeking an electronic version of DXN just because it's cool high tech, or you think it will be cheap, or... it would be easy to get for free because a member could forward it to you and you would not have to pay. Those are the WRONG reasons. The right reasons should be because we can more effectively get OUR (your and mine) info to the rest of the membership faster, and more accurately. We can save time in the retyping and formatting of information to editors. (Remember, the people who put it together are like you. Their time is as important as yours). If people don't submit info/logs/tips/articles/material, no publication (print or electronic) will survive. Any organization is only as good as the quality of the material put into it. The efficiency of publications is proportional to the methods used to reduce labor and time provoking activities. Having said that, why don't we put some ideas together so information from you can be posted more efficiently to the list and directed to the appropriate editors for publication in DXN?

Russ Edmunds <wb2bjh@nrcdxas.org>: Nothing to take offense at, but I don't see how almost no DX Tips on the DX Tip list speaks well?!? "I fear that even with an electronic DXN there will be those who will still not find it acceptable because it's not instant enough." That was exactly one of my prior points, and is very connected to the DXTip issue. And Phil already shared with us IRCA's timing electronic vs. print, so we have something to chew on... "The right reasons should be because we can more effectively get OUR (your and mine) info to the rest of the membership faster, and more accurately. We can save time in the retyping and formatting of information to editors..." Essentially, I'm in complete agreement!

Frederick R. Vobbe: My point exactly. Why do we need the urgency of information when we have something in place that nobody uses? And as I pointed out earlier, if people really want a great publication, then start submitting loggings and info to the list and to editors!

Kevin Redding <lwdxer@juno.com>: "It seems to me that the NRC has two things that work well. DX News in print is great, and our lists are "the most* efficient way to transfer info (albeit they are not used to their full potential). If you have a tip, put it in the DXTIP so those of us who are in the list can get the alerts." Perhaps you could tell those not on the list as you and I are, how to subscribe to the DXTIP list. I post on it from time to time and it may help a lot of us to hear a new station we have been trying for over a long period of time. "Perhaps we should entertain the idea of a web page for submitting your loggings, which would automatically send them to the DDXD editors and post them in a special digest edition or web page." I think the lists are OK as is.

WBE

Classik Jazz • Blues • Gospel

If you get too many lists, then there is little discussion because everything becomes too specialized. "What about a putting all stories, articles, FCC news into a separate list?" Fred, I belong to the Whazup list. What is that list for if not for that kind of stuff? That would be a good list for those who don't want all the mail traffic but would get a news type thing made from stuff off the other lists. I still don't know what the ultimate use of that list is. It's a bit fuzzy to me. "The right reasons should be because we can more effectively get OUR (your and mine) info to the rest of the membership faster, and more accurately. We can save time in the retyping and formatting of information to editors." These are the reasons that I gave IRCA last year. I hope that its working out for them. "If people don't submit info/logs/tips/articles/material, no publication (print or electronic) will survive." What is amazing to me is that we have @750 people. Only a TINY percentage post or send in loggings. With that many people each issue of the DXN should be the size of a phone book if they would send in logs and stories.

Frederick R. Vobbe: "Perhaps you could tell those not on the list as you and I are, how to subscribe to the DX TIP list." Just send a message to DXTIP-Subscribe@nrccdxas.org. Don't put anything in the subject box or body, just send it with that address. You "may" get a MLM response back checking to make sure you did send it, and all you have to do is reply to it and send it. The same applies for dxc@nrccdxas.org, idxd@nrccdxas.org, gydx@nrccdxas.org, and the other lists. "I think the lists are OK as is. If you get too many lists, then there is little discussion because everything becomes too specialized." Then what about a daily or bi-daily posting to am@nrccdxas.org of all the loggings submitted, with a cc: going to the DDXD editors? "Fred, I belong to the Whazup list. What is that list for if not for that kind of stuff?" It's for telling people what is up (hence Whazup) at the NRC with news and notes. I don't really like to post ads and info to the AM or FMTV list otherwise someone will take that as a cue to post their ads and website recommendations, and then we really have problems. Would everyone rather see the stories and FCC stuff in Whazup? "What is amazing to me is that we have @750 people. Only a TINY percentage post or send in loggings. With that many people each issue of the DXN should be the size of a phone book if they would send in logs and stories." I agree, and I suspect that it's the "someone else will do it" theory. For every person that thinks "someone else will do it", there are 100 or so that are thinking of that fellow and saying "someone else will do it". I don't know if putting a reporting form in DX News would help or what, but you are right the ratio is small. Same goes for DXAS. There are a few members that kick butt when it comes to tips, information, and submissions. Yet there are others who have been with us for more than 10 years and I've yet to hear a peep out of them. That's fine for me, but like I pointed out to folks at the convention, DXAS editors are not like Matt Drudge. We don't go looking for the story. If someone gives us just a tip, we'll report it, but we don't have the assets to do investigative work. For the DXAS members on the list, just call 419-224-1609 and leave your tip or info. Other members will appreciate it.

Russ Edmunds: "What is amazing to me is that we have @750 people. Only a TINY percentage post or send in loggings." It has almost always been that way. And I'd guess if Fred were to divulge the number of subscribers to this list, it would probably be at least 3 or 4 times the number of different people one could count posting to it in any given week... But look at it this way - if twice or three times as many people reported, either the size of DXN (and hence the work to produce it and also the paper and postage costs, and hence the dues) would have to increase or else there would be limited space and submissions would have to be cut. In almost any nonprofit hobby club, this is normal - the 'readers' largely read, and in so doing, subsidize the remainder. That's not necessarily a bad thing!

Mike Pietruk <pietruk@shellworld.net>: Russ, I think that part of the reason that the number of contributors is small lies with a number of factors. One assumption that is made when someone joins the NRC or IRCA is that they are active in DXing. While I occasionally do seek a catch, I find the discussions more valuable as a tool to keep up with what's happening in radio; and now, with so much audio available on the web, find little practical value in listening to a scratchy broadcast of a far away game when I can get it in full-quieting FM audio via the net. Now, thanks to the net, I can now, in many instances, personally tune into what folks are writing about rather than to hope that some late night, when I'm plagued with insomnia, I can pick it up for a couple of minutes. I think you might be surprised that many subscribers are interested in radio first and foremost rather than pure DXing.

Russ Edmunds: Actually, I'm not sure that I would be surprised, as I've been aware of that, although that only accounts for some of those who don't appear to be active. For instance, there are probably a number whose interest is primarily DX but who are relatively inactive. And I'm sure there are a number of other reasons as well, which is fine!

Frederick R. Vobbe: That is a good point, Mike. It may also surprise you that many people aircheck, listen to SW radio, and play around with expensive HI-FI equipment. The serious DXers have no problem dropping \$750 to \$3,000 for radios nor spend money on trips just to find a quiet DX spot. That's what makes this hobby interesting, and yet confusing. When we tried an aircheck column on the DXAS, despite people yelling "we want it", there was little support. And when I have read Glenn Hauser's, DXPI, or Media Network's sked on the mag, that will always yield several people asking me not to waste time on shortwave issues. So...as an editor, we walk a relatively thin line. The only way we can guide the magazine(s) is having input from those that support it. Support comes in not

WOKY
AM 1330 920

only someone saying what they like, but also by how they contribute to a publication. I'm more likely to support changes where the membership can prove there is and will be support versus an idea that someone wants to try.

Paul Swearingen <PlsBCBDXER@aol.com>: Add "motivation of editors" to the "thin line" factor. Several times I've tried to listen to the membership and put ideas into print, only to find that recruiting editors was difficult, or "training" them to follow my ideas (which I hope parallel those of the membership) was even more problematic. And let's not even discuss the fact that I'm not only publishing DXN but editing two infrequent columns (DDXA and IDXA) and temporarily editing an every-issue column, DDXD-E, for which I received not a single volunteer when the regular editor had to back out for a few months, due to family obligations. In spite of the fact that right now DXN has the finest bunch of editors I've ever worked with, it's rather difficult to tweak peoples' "comfort zone" to get them to accept new ideas, both editors and general members.

Russ Edmunds: "If NRC does go to electronic distribution, it needs to be certain it uses a platform that supports all major OSs." And that's another dissent to the statement made here yesterday about how standards were becoming more established. There are probably very very few ways to do a project like the log which would be workable with just the more common OS's. And, if Linux offered significant advantages to or was more usable by less advanced users, it would also be even more prevalent than it already is. I know a number of people who want an alternative to anything Microsoft for a variety of reasons, but wouldn't be able to handle Linux - myself included, hi.

Doug Smith <w9wi@bellsouth.net>: I'm not referring only to Linux here. I know Paul is a Mac fan, and there are others in the club. The other problem is that proprietary tools and formats (like Word Perfect and Adobe Acrobat) sometimes cease to be backwards-compatible. That forces users of older versions to upgrade against their will. (especially frustrating when the upgrade won't run on their hardware or older OS version!) Finally, these proprietary formats often stuff a lot of unnecessary extra information into the files. Whether you're a Microsoft fan or not, there's a lot to be said for using the most universal file format possible. (besides, with Star Office I can read just about any Microsoft file anyway!)

Frederick R. Vobbe: So can I, but what about the rest of the people on the list? Again, let's not get so elitist that in our quest to have a snappy e-publication that we ace out people. Personally, I would see the only viable publication being in text only, like a digest, so that *anyone* could read it without a specific platform, or the need to install a software package of any sort.

Doug Smith W9WI: (the Star Office comment was meant essentially facetiously) Text or HTML. Those are the two essentially universal formats. Text is slightly more universal (accessible on *very* old machines like the C64 which don't support web browsers) while HTML supports the attachment of pictures & charts. I would definitely avoid any other format.

Doug Smith W9WI: "But I don't think that having an exact copy of an issue of DXN somewhere in cyberspace is what we're talking about." I don't know what others are thinking, but actually an exact copy of the paper DXN *is* what I was thinking of. The hyperlinks would work (which of course they can't in a paper DXN!) but otherwise we'd be looking at an electronic copy of the printed bulletin. Not actually "somewhere in cyberspace" but emailed directly to paid subscribers.

Paul Swearingen: Aaack! I may be missing something here, but I have to go back to my reading-DX-News-on-the-laptop-while-seated-in-the-bathroom concept. E-searching the content of a series of DXN's notwithstanding, I fail to see any advantage. How 'bout an interactive DXN on a web site - with each station logo hot-linked to streaming audio of the station's ID? Or each unID hot-linked to the originator's web site, which would host the audio clip of the unID for perusal? 3D diagrams of construction projects, with full color-coded components? Promos for Publications Center items in streaming video? Wowie zowie! The concepts make me so tired that I'm going to have to hit the sack just so I can muster up enough strength to finish #2, a mere 24-pager in b&w.

Russ Edmunds: Now it's my turn to go "Aack!". I'd think the last thing we'd want to do would be hot-link to streaming audio of station ID's. We have enough lazy/sloppy/fraudulent (you pick) reporters to DXN right now! And audio clips of unID's linked to originator's websites? That's be a small fraction of even this small fraction on the list. I have no idea of why individuals want to have their own websites, although I know many who have them. Not me! Hope your comments were at least somewhat in jest, Paul...

Paul Swearingen: Only somewhat. And partially in response to those who think I still put DXN together with a club and rocks, hi.

W9WB
1690 AM RADIO

Team Effort ...

That's what makes the NRC so great! And all information, contributions, and editing for DX News, DX Audio Service, and all publications is done by unpaid volunteers as part of a team. Perhaps you have a little time to give to your club... if so, please write to Ken Chatterton - P. O. Box 164 - Mannsville, NY 13661-0164, and let him know what talents and time you can offer to the club. Updates to the NRC AM Log are always needed. Why not write to Ken today?!

Target DX

R. J. Edmunds
753 Valley Rd. w2bjh@nrcdxas.org
Blue Bell, PA 19422-2052

DX'ing 'smart', with shared tips and requests by NRC members

Welcome to another edition of Target DX! This time, the focus is on Pre-Sunrise Authority (PSRA) and Post-Sunset Authority (PSSA), both of which have been topics of recent discussion on the listserv. Remember to send your questions or your suggestions for future topic-oriented columns to me either via the NRCDXAS listservs, by off-line email or by regular mail!

Back in the 1950's and early 1960's, there were essentially four basic types of operations permitted – full (or unlimited) time, daytime, limited time and shared time. The first two being somewhat obvious, I'll start with the third. Limited time operations were granted to a small number of stations which were authorized to operate on schedules which were less than full time but more than daytime. Most of these were on designated Clear Channels, where a second station, usually at a large distance from the first, was permitted to operate during the day, but were required to sign off at a specified time each month, usually determined by the time of local sunset at the first station, rather than at their own local sunset. Conversely, the Limited Time stations were often required to sign on at times other than their local sunrise, depending upon the location of the co-channel station they were required to protect. The fourth type of operation covered situations where two or more stations within a close geographical area were licensed to the same frequency and permitted to share hours of operation. Sometimes these stations utilized the same technical facilities, while other times, they did not.

Another group of stations, by virtue of their proximity to stations on the Canadian border and by operation of treaty, were required to either reduce power and/or change antenna pattern prior to local sunset in order to provide protection from interference to those Canadian stations. These were designated as 'Canadian-Restricted' operations. Similarly, there was also another group of stations which provided similar protections to specified co-channel US stations. This group was designated as 'Critical Hours' operations. Both differed from the previously mentioned Limited Time stations in that they were not always required to leave the air to avoid creating interference as the Limited Time stations were.

Each of the various groupings other than full time were brought about at various times in an attempt to increase the number of stations available on each frequency, as well as the number of hours they could operate. This is of course the same force which has driven many subsequent changes we have seen over the years, which included the introduction, in the late 1960's, of Pre-Sunrise Authority. (It should be noted, however, that no additional Limited Time stations could be licensed after 1954, nor any new daytime stations after December, 1987.)

The original idea behind the PSRA was to permit daytime stations, whose local sunrise in midwinter could be 8:00 AM local time or later, to sign on as early as 6:00 AM with reduced power until their actual local sunrise time so as to be able to better serve their communities. The rationale behind the PSSA, which came a few years later, was similar, in that local sunset in some parts of the country in midwinter could be as early as 4:00 PM. The PSSA permits operations for a period of up to two hours after local sunset. In the interests of objectivity, it must be mentioned that morning and evening drive time are the two most lucrative times of the day for most stations. As with many general rules, there are several exceptions as dictated either by international treaty, or by specific requirements protecting co-channel fulltime stations on the clear channels. In addition, protected stations were permitted to contest PSRA or PSSA authorizations, which frequently led to formal hearings and additional engineering studies.

PSRA's and PSSA's were often assigned not just to daytime-only stations, but to a number of fulltime stations as well. If a fulltimer had an authorized nighttime power of less than the 500 watt maximum for PSRA and PSSA, or if it were directional at night in such a way as its coverage under a nondirectional 250 or 500 watt PSRA or PSSA would cover a greater area than the directional nighttime pattern would at greater power, then they would opt to use these programs. Similarly, when the FCC granted nighttime operations to the majority of daytimers a number of years ago, the majority of those stations retained the use of their former PSRA and PSSA authorizations.

In both cases, powers for these additional hours of operations are calculated by the FCC based on a number of interference factors, and in some cases, there are also limitations on hours beyond those stated above. The absolute maximum permissible power under either program is 500 watts. Today, stations not

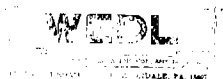

need to apply for either PSRA or PSSA, nor are they required to use them when they are issued. In the earlier years of both programs, however, stations were required to apply for their authorizations, providing engineering data proving that they could accomplish it without causing interference. All stations choosing to use these extended authorizations *are* required to notify the FCC of their intended use, and, in all cases where the authorized power is less than the smallest of their normal daytime, Critical Hours or Canadian-Restricted authorized power, to document *how they intended to achieve the reduced power level*.

This last follows some of the recent discussion on the listserv as to the problems which caused some stations to choose not to use their PSRA or PSSA, or else to use higher powers than authorized. With many stations authorized for PSRA or PSSA powers of less than 10 watts, this wasn't the only problem, because even if a station could reasonably obtain the correct power, its coverage often was so marginal that using it didn't pay to use it. Today, a similar situation exists with regard to many of the night powers authorized for former daytime stations.

A major problem for DX'ers is that the FCC has not produced any public records of the authorized powers and/or stations for PSRA and PSSA operation in many years. This is further complicated by several factors: 1) as additional new stations or station changes become operational, a number of PSRA and/or PSSA powers for other stations must be recalculated; 2) not all stations have chosen to use these authorizations, some not notifying the FCC of their intentions; 3) no formal rules appear to have been made concerning PSRA's and PSSA's for those former daytime stations later granted small nighttime powers; and 4) many station owners and operators do not understand nor even know the requirements of these authorizations, and therefore do not properly comply with them. The result is that many DX'ers report stations as operating outside of normal daytime hours with day power when a number of these may in fact be legally operating with a PSRA or PSSA.

Given the considerations noted above, it will usually not be possible to determine what conditions actually apply in many cases.

One result is a change in the way DX'ers must approach sunrise and sunset DX. The main consequence is that in many cases neither a sign-on or sign-off announcement nor anthem will be heard from many stations at their local sunrise or sunset times. On the other hand, however, there may be more of these available at 6:00 am local time and at two hours past local sunset. Of course, with the addition of low power nighttime operations for many stations, there are a lot fewer sign-ons and sign-offs in general. It is also undeniable that all of these situations contribute greatly to increasing the number of stations to wade through at any given time to find the ones we're searching for, but such is the nature of DX today. It has become somewhat more difficult to plan one's DX sessions than it used to be, and more of a case of being fortunate enough to be in the right place at the right time, which is, after all, one of the basics of the hobby which has always been a factor.

As can be seen from the foregoing discussion, it is often nearly impossible to say with certainty that a given station is operating illegally with daytime facilities unless the reception is either prior to 6:00 am at the station or more than 2 hours past its local sunset. Further, like many aspects of the hobby, these situations can provide DX for some and more pests for others, as can also be said of the confusion on the part of station personnel which sometimes may result in illegal operation.

I'd like to thank Jerry Starr and Wayne Heinen for providing me with some of the details of how the programs worked initially and also as to how these programs were affected by subsequent authorizations. - RJE

The NRC AM Log on a disk. The NRC is offering this service primarily for sight-impaired members; but NRC members (ONLY) may purchase this PC-formatted, 3.5-inch disk for \$6.00 postpaid. The list contains only Frequency, Call letters, State, City, Antenna, Day Power, Night Power, Additional Powers, Permits, Time Zone, and Stereo Operation and is current with the 20th Edition of the NRC AM Log. Order from the NRC Publications Center - Box 164 - Mannsville, NY 13661. NY orders, please add sales tax.

NRC's Antenna Manuals
Now completely revised and up-to-date!
Antenna Reference Manuals, Vol. 1 and 2,
\$6.95 each (\$9.95 to non-members)
Loop Antenna Design & Theory,
\$8.50 (\$12.95 to non-members)
Order from NRC Publications - P. O. Box 164 - Mannsville, NY 13661. NY orders, please add sales tax.



Confirmed DX'er

Ken MacHarg 112047.3007@compuserve.com
186 NE 109th St.
Miami Shores, FL 33161-7042

Your successes in obtaining QSL's and other station items

Welcome again to Confirmed DX'er. The last column evidently disappeared into cyberspace for about three months until Paul and I discovered that, while I sent it, he never received it. Sorry for the delay in getting those to you. That all meant, however, that I sat on new contributions waiting for the last column to appear. So, we have a long list of them this time around—in fact, it is so long, I have divided it into two columns the second of which will appear in a later issue. So, if your reports aren't here, hang in there! Thanks to all who participate in this venture.

Let's start out this time with verifications from other countries since we seem to have a lot of them, thanks especially to Patrick Martin.

OUTSIDE OF THE USA & CANADA

Argentina, Red 92, 1630, La Plata, full color jpeg E Mail QSL in about an hour after follow up. My 2nd Argentina MW QSL. Really nice full detailed QSL. Attached letter from: Juan Marcelo Escande LW2ENS). E Mail address: escande@red92.com. This really made my day! (Martin—OR)

Australia, 4RF, 1629 Brisbane, QSL received, my 218th Aussie QSL in 17 days for taped report to: John Wright - 4/33 Kerrie Crescent - Peakhurst NSW 2210, Australia. (Martin—OR)

México, XEDT, 1080, Cd. Cuauhtemoc, n/d letter in 168 days for f/up. V/s Federico Gonzalez de la Vega, Gerente. (Wilkins—CO)

Mexico, XEHHL, 640, Hidalgo del Parral, n/d letter, stickers in 56 days for f/up. V/s Hector G. Lujan Servin, Gerente General. (Wilkins—CO)

Mexico, XEUT, 1630, Mexicali, certificate, along with letter in SS, stickers for FM, program Schedule, and poster in 3 weeks for \$1. V/s: Martha Adriana Márquez-Jefa de Radio Universidad and Gabriel Estrella Valenzuela-Director General. Address: UABC Radio, 233 Paulin Avenue, PO Box MSC 5163, Calexico CA 92231-2646. (Martin—OR)

New Zealand, Samoan Capital Radio, 783 Wellington, verie letter in 35d from M. Lui, Station administrator, along with station profile, for mint stations. Address: Level 2, Rostrevor House, Cnr Vivian/Marion Sts. PO Box 6647, Te Aro, Wellington, New Zealand. New Zealand QSL #102. (Martin—OR)

New Zealand, 88 Country, 1593 Christchurch, f/d letter in 17 days from taped report. V/s: Honest John Peterson-CE/GM. 2.5 KW Address: P.O. Box 1603, Christchurch NZ. New Zealand QSL #104. (Martin—OR)

CANADA

Alberta, CKUA, 580, Edmonton, QSL e-mail in 2 days from: Larry King, [Certainly not *the* Larry King??? -Ken] CKUA Radio. E-mail address <Larry.King@ckua.org>. I have this verified from 1965 from Seward AK, but I have wanted to re-verify it from Oregon. CKUA for years have not replied to any of my reports from Oregon. (Martin—OR)

British Columbia, CKMO, 900, Victoria, e-mail QSL in 1df. V/S: Clint Lalonde e-mail address: ckmo@camosun.bc.ca (Martin—OR)

Ontario, CHWO, 1350, Oakville, f/d personal letter in 7 months for mint stamp (used). V/s S. Hamnett, Traffic Manager. (Walker—MI)

Ontario, CJMR, 1320, Missauga, f/d personal letter in 7 months for mint stamp (not used). V/s S. Hamnett, Traffic Manager. *Verifications for CHWO and CJMR were done on the same letter, on CHWO stationary. (Walker—MI)

USA

Alaska, KSDP, 830, SAND POINT, f/d QSL card and letter, along with my pp/d form and fridge magnet, sticker, etc. V/S: Ronald Schoedel III, General Manager. He is also a DXer and welcomes reports. He is currently going through the files answering all the reports he can that haven't been replied to. Address: Aleutian Peninsula Broadcasting Inc., Post Office Box 328, San Point AK 99661. Now I have KSDP QSL'd on 840 with 250w and on 830 with 1 KW. (Martin—OR)

California, KYNO, 1300, Fresno, Radio Guadalupe, rec. nice QSL letter with coverage map in 17d for taped report and letter in SS. The reply was in EE. V/s: Jess M. González-Prog. Promo. Director. Address: 2125 N. Barton



Avenue, Fresno CA 93703. (Martin—OR)

Colorado, KRCX, 1530 Denver. PFC, letter, t-shirt in 74 days for f/up. V/s John P. Hickey, Faculty advisor. This is the low-power Regis University stn. (Wilkins—CO)

Colorado, KUBC, 580, Montrose, verification letter in 10 days for taped report. Address: PO Box 970, Montrose, CO 81401, V/S: Jim Frank-CE. (Martin—OR)

Florida, WPSL, 1590, Port St. Lucie, form letter in 450 days from Greg and Carol Wyatt-Owners. Earlier Greg had sent my ppd/card back. Also sent bumper stickers. Address: 8245 Business Park Drive, Port St. Lucie FL 34952. (Martin—OR)

Idaho, KWAL, Wallace, second QSL. This time they returned my ppd/card. V/s Paul E. Robiner (no title). Address: P.O. Box "U", Osburn ID 83849.in 37d. (Martin—OR)

Indiana, WOWO, 1190, Fort Wayne, form letter in 23 days from: Jack Didier, Dir. of Engineering. Address: P.O. Box 6000, Fort Wayne IN46896 (Martin—OR)

Illinois, WSDZ, 1260, Belleville, f/d E-mail verie in 10 days for Snail Mail f/up. Sender was Guy Inverferth, Business Mgr. (Wilkins—CO)

Michigan, WFNT, 1470 Flint, ppd/post card in 7 days. V/s is Mort Moore (spelling?), Program Director. (Walker—MI)

Michigan, WKWM, 1140, Kentwood, n/d letter verifying reception of their sister station, WJNZ (1680) in 2 weeks, and bumper stickers for WKWM and WJNZ for mint stamp (used). V/s Tricia Smith, Office Manager. (Walker—MI)

Mississippi, WJNT, 1180 Pearl, form letter with IRCA logo on the top in 7 days from taped report. V/s: Stan Carter-CE. Address: PO Box 1248, Jackson MS 39215-1248. (Martin—OR)

New Mexico, KTHR, 1230, Gallup, f/d letter in 9 days. V/S Justin Stokes. (Wilkins—CO)

Nevada, KKVV, 1060, Las Vegas, letter in 7 days. V/s Sharon Martin-Adm. Assistant. Received with 43 watts night power. Sent taped report. Address: 3185 S. Highland Dr. #13, Las Vegas NV 89109. (Martin—OR)

North Carolina, WPAQ, 740, Mount Airy, letter and station information in 6 days, signed Ralph D. Epperson, Licensee. Address: PO Box 907, Mount Airy NC 27030. (Conti—NH)

North Dakota, KQWB, 1660, Fargo, full data letter, info sheet describing format, coverage map in 16 days, V/s Brian Whalen, APD, Address: P.O.B. 9919, Fargo 58106-9919. (Griffith—CO)

North Dakota, KQWB, 1660, West Fargo, new X Band QSL in 13 days from: Mark Borchert CE. Mentioned in letter they moved the 1550 up to 1660, so apparently 1550 is silent. Also said they are 10 KW day / 1 KW nights ND. Address: PO Box 9919, Fargo ND 58106-9919 (Martin—OR)

Ohio, WDLR, 1550 Delaware, f/d personal letter on blank page in 5 days for mint stamp (used). (Walker—MI)

Ohio, WTAM, 1100, Cleveland, f/d letter in 7 days for mint stamp (not used). V/s Ray Davis, Program Director. (Walker—MI)

Oklahoma, 1520 KOMA OK, OKLAHOMA CITY, QSL card and bumper stickers in 10days. Address: PO Box 14818, Oklahoma City, OK 73113-0818. (Martin—OR)

Oregon, KEWS, (frequency?), Portland, blue QSL card in 7days. A really nice card with a map of Oregon. This station hasn't had a card since the KGW days. I had QSL'd them with a ppd/card in the past. Address: 4949 SW Macadam Ave, Portland, OR 97201 (Martin—OR)

South Dakota, KOSZ, 1570, Vermillion, letter in 241days. V/s: Kevin Culhane-GM. Mentioned since they changed format a few months back they had been busy. They are now KVTK, ESPN Sports. Address: 1407 East Cherry Street, Vermillion, SD 57069. Heard with 71 watts. (Martin—OR)

Texas, KDXX, 1480, Dallas. Ppd/letter, map in 44 days for f/up. V/s David Stewart, D.o.E. (Wilkins—CO)

Texas, KTCK, 1310, Dallas, f/d 8x11 dual KTCK/KTBK QSL sheet w/"The Ticket" logo in 79 days for f/up. V/s Hue Beavers. (Wilkins—CO)

Texas, TX WTAW 1620 College Station. F/D card in 12 days. (Wilkins—CO)

Utah, KFNZ, 1320, Salt Lake City, ppd/card in 14 days for f/up. (Wilkins—CO)

Washington, KFLD, 870 Pasco, letter and QSL form along with bumper sticker and business card in 7 days. V/s: Ronald S. Sweatt-Dir of Eng. Address: 2621 West A Street, Pasco WA 99301 (Martin—OR)

Other good stuff

California, WNEG268, 1670, Sacramento, HAR station, E Mail QSL in 1d after f/up. V/s: Michele Cormick. Address: michele@mnmpr.com. (Martin—OR)

Colorado, WPP2664, 1610 Loveland, ppd/card in 86 days for f/up. "Loveland Information Radio" .V/s Andy Hiller, Public Info. Officer. (Wilkins—CO)



Graveyard Achievements

Distance records for stations logged on graveyard frequencies

Bill Hale phantom2@eazc.net
6124 Roaring Springs Drive
North Richland Hills, TX 76180-5552



Logged from Jan 1, 1960 to Present
Date of Last Update: November 22, 2000

indicates record held from Alaska or Hawaii

* indicates record held by DXer from North America (excluding Alaska)

Station	City	DXer	DX Location	Miles
WAUD	AL Auburn	Ernie Wesolowski	Omaha, NE	836
WJBB	AL Haleyville	Steve Francis	Alcoa, TN	232
WBHP	AL Huntsville	J.W. Bay, Jr.	Drexel Hill, PA	718
WHOD	AL Jackson	Niel Wolfish	Toronto, ON	957
WNUZ	AL Talladega	Steve Francis	Alcoa	193
WTBC	AL Tuscaloosa	Dave Whatmough	Hamilton, ON	805
KIPW	AK Sitka	Jack Woods	Douglas, AK	#91
KVAK	AK Valdez	Esa Hänninen	Lemmenjoki, Finland	3453
KSUN	AZ Bisbee	Ernie Wesolowski	Omaha	1022
KAAA	AZ Kingman	John Johnson	Sheridan, WY	761
KAMJ	AZ Phoenix	Jeff Tynan	Parker, CO	586
KATO	AZ Safford	Ernie Wesolowski	Omaha	950
KINO	AZ Winslow	Phil Bytheway	Seattle, WA	1055
KFPW	AR Ft. Smith	Jerry Starr	Youngstown, OH	855
KBTM	AR Jonesboro	Ron Bailey	Shelby, NC	513
KGEO	CA Bakersfield	Richard E. Wood	Keaau, HI	#2444
		Tim Hall	Chula Vista, CA	*217
		Art Blair	Folsom, CA	347
KSZL	CA Barstow	Art Blair	Folsom, CA	347
KIBS	CA Bishop	Nancy Johnson	Aberdeen, WA	722
KXO	CA El Centro	Richard E. Wood	Keaau	#2595
		Carl Dabelstein	Tucson, AZ	*271
KDAC	CA Fort Bragg	Carl Dabelstein	Lihue, Hawaii	#2414
		Nancy Johnson	Aberdeen	*522
KGfJ	CA Los Angeles	Bruce Reynolds	San Jose, CA	305
KPRL	CA Paso Robles	Frank Merrill	Nenana, AK	#2321
		Tim Hall	Fillmore, UT	*513
KRDG	CA Redding	Phil Bytheway	Seattle	487
KWG	CA Stockton	Richard E. Wood	Keaau	#2388
		Phil Bytheway	Seattle	*669
KEXO	CO Grand Junction	Shawn Axelrod	Winnipeg, MB	921
KBRR	CO Leadville	Mike Hardester	San Marcos, CA	738
KDZA	CO Pueblo	Niel Wolfish	Winnipeg, MB	871
		Shawn Axelrod	Winnipeg	(Tie) 871
KBCR	CO Steamboat Springs	Shawn Axelrod	Winnipeg	846
KSTC	CO Sterling	Mike Hawk	Omaha, NE	371
KGEK		Ernie Wesolowski	Omaha	(Tie) 371
WINF	CT Manchester	Jeff Falconer	Clinton, ON	473
WGGG	FL Gainesville	Barry McLarnon	Ottawa, ON	1143
WONN	FL Lakeland	Don Trelford	Runaway Bay, Jamaica	728
WMAF	FL Madison	Steve Francis	Alcoa	356
WSBB	FL New Smyrna Beach	Barry McLarnon	Ottawa	1164
WNVY	FL Pensacola	Ron Schiller	Lighthouse Point, FL	519
WCNH	FL Quincy	Barry McLarnon	Ottawa, ON	1128
WJNO	FL West Palm Beach	UK DXpedition	Sheigra, Scotland	4121

WCKJ	GA Augusta	Marc DeLorenzo	Hyannis, MA	*1172
WBLJ	GA Dalton	Dave Braun	Falls Church, VA	462
WXLI	GA Dublin	Dave Whatmough	Hamilton, ON	648
WFOM	GA Marietta	Jeff Falconer	Clinton	771
WSOK	GA Savannah	J.W. Bay, Jr.	Drexel Hill	657
WAYX	GA Waycross	Jeff Falconer	Clinton	799
KBAR	ID Burley	Harry Hayes	Thornhurst, PA	784
KORT	ID Grangeville	Nancy Johnson	Aberdeen	578
		Esa Hänninen	Lemmenjoki	4277
		Shawn Axelrod	Swan River, MB	*796
KRXK	ID Rexburg	Esa Hänninen	Lemmenjoki	4360
		Shawn Axelrod	Swan River	*749
WJBC	IL Bloomington	Shawn Axelrod	Winnipeg	750
WMRZ	IL Moline	Esa Hänninen	Lemmenjoki	4165
		Shawn Axelrod	Winnipeg	*650
WHCO	IL Sparta	Shawn Axelrod	Winnipeg	879
WJOB	IN Hammond	Niel Wolfish	Winnipeg	773
WSAL	IN Logansport	Niel Wolfish	Winnipeg	855
WTCJ	IN Tell City	Barry McLarnon	Ottawa	764
WBOW	IN Terre Haute	Shawn Axelrod	Winnipeg	879
KFJB	IA Marshalltown	Ron Schiller	Monmouth Beach, NJ	994
WHIR	KY Danville	Jeff Falconer	Clinton	445
WHOP	KY Hopkinsville	Steve Kennedy	Coal Township, PA	652
WANO	KY Pineville	Steve Kennedy	Coal Township	479
KLIC	LA Monroe	Frank Merrill	Milan, MI	803
WBOK	LA New Orleans	James Dale	Rosemount, MN	1034
KSLO	LA Opelousas	Carl Dabelstein	Lincoln, NE	755
WBME	ME Belfast	Don Voorhies	Oswego, NY	380
		Ron Schiller	Monmouth Beach	(Tie) 380
WSJR	ME Madawaska	Andy Rugg	Montreal, QU	283
WITH	MD Baltimore	Steve Francis	Alcoa	464
WALI	MD Cumberland	Jeff Falconer	Clinton	310
WMNB	MA North Adams	Jim Renfrew	Rochester, NY	227
WNAW		Barry McLarnon	Ottawa	(Tie) 227
WESX	MA Salem	John Campbell	Bridestow, England	3195
		NF DXpedition #5	Cappahayden, NF	*928
WNEB	MA Worcester	Morris Sorensen	Emsdale, ON	436
WCUZ	MI Grand Rapids	Niel Wolfish	Winnipeg	716
		Shawn Axelrod	Winnipeg	(Tie) 716
WGRY	MI Grayling	Don Voorhies	Oswego	415
WIKB	MI Iron River	Barry McLarnon	Ottawa	621
WMPC	MI Lapeer	Bill Dvorak	Madison, WI	310
WOO	MI Sault Ste. Marie	Morris Sorensen	Leaf Rapids, MB	955
WSTR	MI Sturgis	Joe Fela	Newark, NJ	588
WCLK	MN Cloquet	Bruce Reynolds	Warrensburg, MO	556
KGHS	MN International Falls	Ernie Wesolowski	Omaha	526
KYSM	MN Mankato	Morris Sorensen	Leaf Rapids	740
KMRS	MN Morris	John Wilkins	Wheat Ridge, CO	618
KTRF	MN Thief River Falls	Morris Sorensen	Leaf Rapids	980
KWNO	MN Winona	Steve Kennedy	Coal Township	804
WCMA	MS Corinth	Barry McLarnon	Ottawa	983
WHSY	MS Hattiesburg	Charles Reh	Leamington, ON	826
WSSO	MS Starkville	Charles Reh	Leamington	683
KODE	MO Joplin	Shawn Axelrod	Winnipeg	880
KLWT	MO Lebanon	Carl Dabelstein	Lincoln	309
		Bob McCoy	Lincoln	(Tie) 309
KWIX	MO Moberly	Esa Hänninen	Lemmenjoki	4336
		Shawn Axelrod	Winnipeg	*747
KOBB	MT Bozeman	Shawn Axelrod	Winnipeg	703
KHDN	MT Hardin	Frank Merrill	Milan	1213
KXI.O	MT Lewistown	John Johnson	Sheridan	197

KLCB	MT	Libby	Nancy Johnson	Aberdeen	396
KTNC	NE	Falls City	Robert Kramer	Chicago, IL	423
KHAS	NE	Hastings	Frank Merrill	Milan	771
KELY	NV	Ely	Tim Hall	Chula Vista	475
KFUN	NV	Las Vegas	Shawn Axelrod	Valhalla Beach, MB	1370
KLBN	NV	Reno	Nancy Johnson	Aberdeen	556
WMOU	NH	Berlin	Joe Kureth	Uniontown, MD	453
WTSV	NH	Claremont	Steve Kennedy	Coal Township	278
WCMC	NJ	Wildwood	Mark Hattam	Sheigra, Scotland	3270
			Jeff Falconer	Clinton	*473
KALG	NM	Alamogordo	Ernie Wesolowski	Omaha	791
KYVA	NM	Gallup	Tim Hall	Chula Vista	509
KFUN	NM	Las Vegas	MB DXpedition &	Valhalla, MB	1120
KRSY	NM	Roswell	Frank Merrill	Macomb, IL	912
WECK	NY	Cheektowaga	Don Lynch	Boston, MA	391
WENY	NY	Elmira	Bill Dvorak	Madison	644
WBZA	NY	Glens Falls	Morris Sorensen	Milton, ON	316
WIGS	NY	Gouverneur	J.W. Bay, Jr.	Drexel Hill	303
WHUC	NY	Hudson	Joe Kureth	Uniontown	254
WLFH	NY	Little Falls	Charles Reh	Leamington	398
WFAS	NY	White Plains	Jeff Falconer	Clinton	433
WSKY	NC	Asheville	Steve Francis	Alcoa	84
WFAI	NC	Fayetteville	Jeff Falconer	Clinton	608
WMFR	NC	High Point	Barry McLarnon	Ottawa	687
WISP	NC	Kinston	J. W. Bay, Jr.	Drexel Hill	348
WNNC	NC	Newton	Karl Jeter	Stone Mountain, GA	210
WCBT	NC	Roanoke Rapids	Shawn Axelrod	Winnipeg	1337
KDIX	ND	Dickinson	Olle Alm	Abisko, Sweden	3935
			Charles Reh	Leamington	*1048
WUBE	OH	Cincinnati	Russ Edmunds	Glen Rock, NJ	564
WCOL	OH	Columbus	Shawn Axelrod	Winnipeg	964
WIRO	OH	Ironton	Shawn Axelrod	Winnipeg	1050
WTOL	OH	Toledo	Ernie Wesolowski	Omaha	651
KADA	OK	Ada	Charles Reh	Leamington	911
WBBZ	OK	Ponca City	Shawn Axelrod	Winnipeg	897
KDOV	OR	Ashland	Pete Taylor	San Francisco, CA	308
KVAS	OR	Astoria	Olle Alm	Abisko	4297
			Richard E. Wood	Keaau	#2550
			Shawn Axelrod	Vancouver, BC	*216
			Tim Hall	Vancouver, BC	(Tie) *216
KZZR	OR	Burns	Olle Alm	Abisko	4410
			Bruce Reynolds	San Jose	*455
KHSN	OR	Coos Bay	Richard E. Wood	Keaau	#2425
KOOS	OR	Coos Bay	Bruce Reynolds	San Jose	434
KRDR	OR	Gresham	Esa Hänninen	Lemmenjoki	4376
KMUZ			Tim Hall	Manning Park Resort, BC*	296
KQIK	OR	Lakeview	Esa Hänninen	Lemmenjoki	4576
			Wayne Heinen	Colorado Springs, CO	*850
KSJK	OR	Talent	Pete Taylor	Tacoma, WA	352
KMUZ	OR	Toledo	Bruce Reynolds	San Jose	517
WBVP	PA	Beaver Falls	Bruce Reynolds	Warrensburg	727
WEEX	PA	Easton	Denis Picard	Trois-Rivieres-Ouest, QU	411
WKBO	PA	Harrisburg	Frank Merrill	Milan	379
WCRO	PA	Johnstown	Andy Rugg	Montreal	447
WBPZ	PA	Lock Haven	Barry McLarnon	Ottawa	305
WTIV	PA	Titusville	Steve Francis	Alcoa	465
WERI	RI	Westerly	Denis Picard	Trois-Rivieres-Ouest	346
WAIM	SC	Anderson	Jeff Falconer	Clinton	631
WXAP	SC	Columbia	Charles Reh	Leamington	561
WOLS	SC	Florence	Barry McLarnon	Ottawa	798
KISD	SD	Sioux Falls	John Johnson	Sheridan	510

WKCE	TN	Harriman	Steve Francis	Alcoa	52
WMLR	TN	Hohenwald	Robert Kramer	Chicago	451
WAKI	TN	McMinnville	Russ Edmunds	Glen Rock	682
KSIX	TX	Corpus Christi	Ernie Wesolowski	Omaha	932
KLKE	TX	Del Rio	Jim Boehm	San Antonio, TX	148
KNUZ	TX	Houston	Frank Merrill	Milan	1072
KERV	TX	Kerrville	Bob McCoy	Lincoln	757
KLVT	TX	Levelland	Jim Boehm	San Antonio	367
KEEE	TX	Nacogdoches	Frank Merrill	Milan	945
KOZA	TX	Odessa	Karl Jeter	Stone Mountain	1066
KGRO	TX	Pampa	Ernie Wesolowski	Omaha	471
KSEY	TX	Seymour	Shawn Axelrod	Winnipeg	1117
KSST	TX	Sulphur Springs	Carl Dabelstein	Lincoln	535
KMOR	UT	Murray	Shawn Axelrod	Winnipeg	948
KOAL	UT	Price	Phil Bytheway	Seattle	801
WJOY	VT	Burlington	Jean Burnell	St. John's, NF	1004
WABN	VA	Abingdon	Barry McLarnon	Ottawa	678
WODI	VA	Brookneal	Jerry Starr	Youngstown	295
WXCF	VA	Clifton Forge	Russ Edmunds	Blue Bell, PA	292
WFVA	VA	Fredericksburg	Andy Rugg	Montreal	537
WNOR	VA	Norfolk	Andy Rugg	Montreal	615
WAMM	VA	Woodstock	Bary McLarnon	Ottawa	472
KOZI	WA	Chelan	Tim Hall	Radium Hot Springs, BC	261
KWYZ	WA	Everett	Esa Hänninen	Lemmenjoki	4268
			Shawn Axelrod	Swan River, MB	*968
KRSS	WA	Spokane	Olle Alm	Abisko, Sweden	4114
			John Johnson	Billings	*443
KREW	WA	Sunnyside	Phil Bytheway	Seattle	139
WLOG	WV	Logan	Don Voorhies	Oswego	390
WKYG	WV	Parkersburg	Barry McLarnon	Ottawa	573
WHBY	WI	Appleton	Joe Fela	Newark	765
WCLO	WI	Janesville	Ron Schiller	Monmouth Beach	796
WXCO	WI	Wausau	Shawn Axelrod	Winnipeg	480
KVOC	WY	Casper	Olle Alm	Abisko	4258
			Frank Merrill	Nanena	#2228
			Tim Hall	Custer State Park, SD	*230
WNIK	PR	Arecibo	Ron Schiller	Monmouth Beach	1574
CBPG	AB	Banff	Tim Hall	Banff, AB	4
CJOK	AB	Ft. McMurray	Esa Hänninen	Lemmenjoki	3509
			Phil Bytheway	Seattle	*781
CIYR	AB	Hinton	Tim Hall	Jasper, AB	42
CJLW	AB	Wainwright	Shawn Axelrod	Winnipeg	630
CKQR	BC	Castlegar	Phil Bytheway	Seattle	251
CJNL	BC	Merritt	Tim Hall	Glacier National Park, MT	355
CFBV	BC	Smithers	Pete Taylor	San Francisco, CA	1200
CHFC	MB	Churchill	Olle Alm	Karesuando, Sweden	3093
			Shawn Axelrod	Winnipeg	*641
CFLN	NF	Goose Bay	Esa Hänninen	Lemmenjoki	2799
CFGN	NF	Port-aux-Basques	Steve Whitt	Sheigra	2295
			Jean Burnell	St. John's	*299
VOAR	NF	St. John's	Jean Burnell	St. John's	4
CFBB	NT	Iqaluit	Esa Hänninen	Ristina, Finland	2766
CKMP	ON	Midland	Robert Kramer	Chicago	445
CJTT	ON	New Liskeard	MB DXpedition &	Arnes, MB	812
CJLB	ON	Thunder Bay	Morris Sorensen	Leaf Rapids	711
CJLP	QU	Disraeli	Don Trelford	Scarborough, ON	414
CHVD	QU	Dolbeau	Esa Hänninen	Lemmenjoki	3334
			Jeff Falconer	Clinton	*573
CJSA	QU	Ste-Agathe-des-Monts	Andy Rugg	Montreal	50
CKLD	QU	Thetford Mines	Charles Reh	Leamington	624
XESCT	BCN	Ensenada	Tim Hall	Chula Vista	52

XEIZ	NL	Monterrey	Jim Boehm	San Antonio	289
ZBM1	BER	Hamilton	Ernie Wesolowski	Omaha	1831
LT2	ARG	Rosario	Pete Taylor	Poipu, HI	7522
ZYI670	BRZ	Joao Pessoa, PB	NF DXPed #4 Team	Cappahayden	3897
ZYJ816	BRZ	Sao Jose, SC	NF DXPed #4 Team	Cappahayden	5160
HJLK	CLM	Cali	LEM96	Lemmonjoki, Finland	6328
			NF DXPed #2 Team	Cappahayden	*3325
YVNT	VEN	Caucauga	Tim Hall	Crane Beach, Barbados	525
CMAD	CU	Artemisa	Frank Merrill	Milan	1330
CMGM	CU	Jaguey Grande	Ron Schiller	Lighthouse Point	267
BEV58	CHN	Taichung	Pete Taylor	Hangzhou, China	426

MB DXpedition [Shawn Axelrod, Wayne McRae]

NF DXpedition #2 Team [Jean Burnell, Mark Connelly, Bruce Conti and Neil Kazaross]

NF DXpedition #4 Team [Jean Burnell, David Clark, Mark Connelly, Bruce Conti, Neil Kazaross, Jim Renfrew]

NF DXpedition #5 -1996 [Jean Burnell, Ben Dangerfield, Bruce Conti, Neil Kazaross, Dave Clark, John Fisher, Jim Renfrew]

UK DXpedition [Steve Whitt, Mark Hattam, Clive Rooms]

LEM96 [Mika Makelainen and Jorma Mantyla]

What a Time-saver - the County Cross Reference

A complete list of counties, parishes, and similar political divisions in the U. S. and Canada. Two lists are included: alpha by county, and by state. Compiled by Bill Hale and designed and produced by Wayne and Joan Heinen. \$6.50 for members, \$9.95, non-member. Order from CCR from the NRC Publications center; NY residents, please include sales tax.

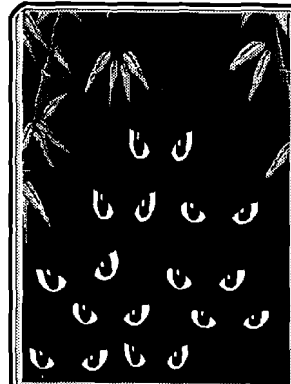

From NRC's DX Audio Service ...

'After Dark 9'

Now available, it includes longer articles not able to be included in normal DXAS programs ... including John Bowker's "1400 Travellog", "Sex and Deception", "Screening Calls", "A Visit to WODI-1230", "Radio from L. P. B." and much more. Two C-90 tapes in a cassette case, only \$5.00 postpaid to members in the United States, \$9.00 to non-NRC/DXAS members. Other areas, please write for pricing. Order from NRC Publications - Box 164 - Mannsville, NY 13661. NY orders, please add sales tax.

AM Broadcast Station Antenna Systems A Basic Guide

Written by NRC'er Patrick Griffith, this book makes it easy for the non-technical DX'er to understand everything about AM broadcast antennas. Over 35 photos. \$13.95 to NRC members (\$17.95, non-members). Order from: NRC Publications - Box 164 - Mannsville, NY 13661 (NY residents, please add sales tax).

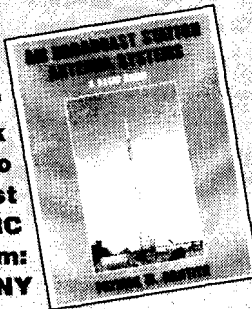

DXP-2 DXpedition Phasing Unit

Mark Connelly, WA1ION

INTRODUCTION

The DXP-2 is one of several phasing units designed to be uncomplicated and easily operable in field-site DXing situations such as in-vehicle operation in less than optimal lighting and space conditions. It is a reduced size and function version of the Superphaser-2. For other compact DXP-family "DXpedition phasing units", see DXP-1 and DXP-3. As noted in other articles, the object of phasing units is to combine the contributions of two antennas at a 180 degree phase relation in order to null out a dominant signal (or noise) and let otherwise-inaudible weaker co-channel and adjacent channel signals come through.

DXP-2 is optimized for medium wave (500 to 2000 kHz) operation, though it may also perform reasonably well on the longwave and tropical band shortwave frequency ranges. Like the DXP-1, this is a compact unit (chassis: 5 x 4 x 3 in. / 12.7 x 10.16 x 7.62 cm) well suited to DXpeditions involving air travel. The DXP-3 is even smaller.

Phase shifting is wideband in nature: tuning is not required. In high-signal urban areas, one could benefit from passive L-C preselection on each of the two input lines ahead of the unit. In most cases, this isn't necessary.

With broadband phasing, a null set up in a given direction is often effective plus or minus 100 kHz or more from the set-up frequency.

Unlike commercial "noise cancellers" by MFJ and JPS-Timewave, the DXP-2 allows independent observation of each input line as well as providing two combined signal (null) positions. This enables the user to balance amplitudes accurately, at least if the receiver has an S-meter, before adjusting the phase for a null. For good null depth, each of the two input lines must have a similar strength of the signal to be nulled.

OPERATING THE DXP-2

Practicing on stable daytime medium wave groundwave signals is the best way to become familiar with the unit's operation. When starting out, choose a frequency having some evidence of a second station under the dominant one.

Initial set-up:

Connect a passive (unpowered) antenna to J1, or connect an active antenna (such as an MFJ-1024 whip) to J3.

Connect the second antenna to J2 (if passive) or J4 (if active).

Connect a DC power source of +12 volts (min.) to +18 volts (max.) to J7.

Connect the receiver, via coaxial cable, to J5.

If desired, connect a spare antenna to J6. This is only connected to the receiver when S2 is OFF.

Set S2 to ON.

Set R1 and R2 fully clockwise.

Amplitude Balancing:

Set R3 to center.

With S1 on 1, observe the level of the dominant signal (or noise) to be nulled. Also do this with S1 on 2.

If the signal level had been greater in the S1 = 1 position, adjust R1 so that the signal level measured with S1 on 1 is equal to that obtained with S1 on 2.

Conversely, if the signal level had been greater in the S1 = 2 position, adjust R2 so that the signal level measured with S1 on 2 is equal to that obtained with S1 on 1.

Nulling:

Set S1 to Null-a and adjust R3 for the best reduction of the dominant signal to be removed. Also do this R3 adjustment with S1 set to Null-b. Leave S1 on the null position which gave the deeper, better-defined null.

Finish up the null by small interactive adjustments of R3, R1, and R2.

Occasionally it may help to set R1 and R2 "fully clockwise minus 1 hour" (e.g. pointers at "4 o'clock" if fully clockwise is "5 o'clock") and then go back to the "Amplitude Balancing" section and proceed forward from there.

REFERENCES CITED

Links to Internet based references may change over time. If a specified link does not work, articles may still be accessible by contacting me directly so I can mail a disk of the article or suggest an updated Web link. Also, in some cases, articles may be available in "hard copy" from the National Radio Club

reprints service.

[1] Superphaser-2 (web = <http://www.qsl.net/wa1ion/sph2/sph2.htm>)[2] DXP-1 (web = <http://members.aol.com/MarkWA1ION/dxp1.pdf>)[3] DXP-3 (web = <http://www.qsl.net/wa1ion/dxp/dxp3.pdf>)

DXP-2 CONSTRUCTION DATA
Table HL-DXP-2: DXP-2 hole-drilling list

X = Horizontal distance, in inches, from the vertical centerline (VCL) on the side observed. Negative values of X are left of VCL, positive values of X are right of VCL.

Y = Vertical distance, in inches, from the bottom horizontal edge of the side observed.

D = Hole diameter in inches.

Hole loci are first marked on the box with a scribe and are then drilled with a .125" or smaller bit. Subsequently, as required, the holes are enlarged to the proper size by using progressively larger bits up to that corresponding to the final desired diameter.

Chassis Box = Mouser # 537-TF-779: 5" X 4" X 3"

LEFT SIDE

Hole #	Desig.	Description	X	Y	D
1	J3	Line 1 Active Ant. In (BNC-f)	-1	1.375	0.375
2	J1	Line 1 Passive Ant. In (BNC-f)	-1	0.4375	0.375
3	G1	grounding H/W - int.&ext.lug	0	0.4375	0.125
4	J4	Line 2 Active Ant. In (BNC-f)	1	1.375	0.375
5	J2	Line 2 Passive Ant. In (BNC-f)	1	0.4375	0.375

TOP SIDE

Hole #	Desig.	Description	X	Y	D
1	S1	Input Select switch - tab	-2	2	0.125
2	S1	Input Select switch - shaft	-1.5	2	0.375
3	S2	Function switch - shaft	-0.25	2	0.25
4	S2	Function switch - tab	0	2	0.125
5	R1	Line 1 Level pot - shaft	0	3.125	0.3125
6	R1	Line 1 Level pot - tab	0	3.125	0.125
7	R2	Line 2 Level pot - shaft	0	0.875	0.3125
8	R2	Line 2 Level pot - tab	0	0.875	0.125
9	R3	Phase Null pot - shaft	1.125	2	0.3125

RIGHT SIDE

Hole #	Desig.	Description	X	Y	D
1	A2	PSA-A amplifier card 2 H/W	-1.25	1.5	0.125
2	J6	Spare Ant. In (BNC-f)	0	2.1875	0.375
3	J7	B+ In (RCA-f)	0	1.5	0.25
4	G2	grounding H/W - int.&ext.lug	0	1	0.125
5	J5	RF Out (BNC-f)	0	0.4375	0.375
6	A1	PSA-A amplifier card 1 H/W	1.25	1.5	0.125

Vendor Codes for Parts Lists

ALD = Allied Electronics = <http://www.alliedelec.com/>

CS = Circuit Specialists = <http://www.cir.com/>

MCL = Mini-Circuits = <http://www.minicircuits.com/>

MOU = Mouser = <http://www.mouser.com/>

NEW = Newark Electronics = <http://www.newark.com/>

RS = Radio Shack = <http://www.radioshack.com/>

It may not be perfect ...

but the NRC AM Log is, simply, the best there is because of your contributions. Why not make the next edition even better? Send all corrections and changes to

Wayne Heinen - 4131 S. Andes Way - Aurora, CO 80013-3831, or nrclog@aol.com. Thanks!

Table PL-DXP-2

DXP-2 DXpedition Phaser upper level parts list (bill of materials)

Item	Quan	Reference	Vendor	Stock Number	Part Description	Notes
1	2	A1, A2	see Table PL-PSA-A		PSA-A Phase Shift Amplifier card	-
2	6	C1 - C6	CS: CK05104K		Capacitor, 0.1 uF	-
3	2	G1, G2	MOU: 572-01881		Screw, 4-40 * .375"	-
4	2	G1, G2	MOU: 572-00484		Hex Nut, 4-40	-
5	4	G1, G2	MOU: 534-7311		Solder lug, #4, internal tooth 2 at each hole	(one inside, one outside)
6	2	-	MOU: 572-00649		Lockwasher, #4, split	mount A1, A2
7	2	-	MOU: 5721-440-1/4		Screw, 4-40 * .25"	mount A1, A2
8	6	J1 - J6	RS: 278-105		BNC jack	-
9	1	J7	RS: 274-346		RCA phono jack	-
10	2	R1, R2	MOU: 31CN405		pot., 50K, linear	-
11	1	R3	MOU: 531-PC16DC-10K		pot., dual, 10K, linear	-
12	1	R4	CS: RA3.3		Resistor, 3.3 ohm	-
13	2	R5, R6	CS: RA150		Resistor, 150 ohm	-
14	2	RFC1, RFC2	MOU: 434-15-222J		RF choke, 2.2 mH	-
15	1	S1	MOU: 10YX034		Switch, 3-pole, 4-pos. rotary	-
16	1	S2	CS: 8011		Switch, DPDT toggle, on-on	-
17	2	T1, T2	MCL: T16-6T-X65		RF transformer, 1:16	-
18	1	-	MOU: 537-TF-779		chassis box, 5" * 4" * 3"	-
19	4	-	MOU: 45KN013		knob (0.94" dia.)	for R1-R3, S1

Misc. items: hook-up wire, buss wire, solder, labels "AS REQUIRED"

Table PL-PSA-A

PSA-A Phase Shift Amplifier card parts list (bill of materials)

Item	Quan	Reference	Vendor	Stock Number	Part Description	Notes
1	3	C1, C3, C6	CS: CK05103K		Capacitor, 0.01 uF	-
2	1	C2	CS: TAC008		Capacitor, Tantalum, 10 uF, 35 V	-
3	1	C4, C7	CS: CK05104K		Capacitor, 0.1 uF	-
4	1	C5	DK: P3151-ND		Capacitor, 150 pF	Panasonic ECQ-P1H151JZ
5	1	H_PB1	RS: 276-1396		Perfboard	cut size 0.9" * 2.0"
6	1	H_SC1	MOU: 5721-440-1/4		Screw, 4-40 * .25"	stock num. = 100 pieces
7	1	H_SL1	MOU: 534-7311		Solder lug, #4, internal tooth	-
8	1	H_SO1	CS: CA-8		Socket, 8-pin DIP	for U1
9	1	H_SP1	MOU: 534-1450C		Spacer, 4-40 * .5"	-
10	10	P1 - P10	CS: T42-1/100		Flea-clip Terminal Pin for .042" hole	-
11	1	Q1	RS: 276-2035		FET, 2N3819	-
12	1	R1	CS: RA4.7		Resistor, 4.7 ohm	-
13	1	R2	MOU: 29SJ250-6.8M		Resistor, 6.8M	-
14	1	R3	CS: 1M		Resistor, 1M	-
15	2	R4, R5	CS: RA2.2K		Resistor, 2.2K	-
16	2	R6, R7	CS: 560K		Resistor, 560K	-
17	2	R8, R9	CS: RA39		Resistor, 39 ohm	-
18	1	R10	CS: RA15		Resistor, 15 ohm	-
19	1	U1	NEW: 06F5241 (or) ALD: 903-3056		Harris HA3-5002-5 Buffer Amplifier, 8-pin DIP	-

plus buss wire, solder "as required"

DRAWINGS (see next four pages)

Not sure about renewing?

Consider these benefits of a membership in the National Radio Club: 720+ pages per year of varied and comprehensive DX and radio information ... reduced prices for publications ... responsive editors ... and the friendliest bunch of DX'ers in the world! Why not send that renewal check to Ron Musco at the membership center today!

DXP-2
DXpedition Phasing Unit
Figure 1 : Input Section

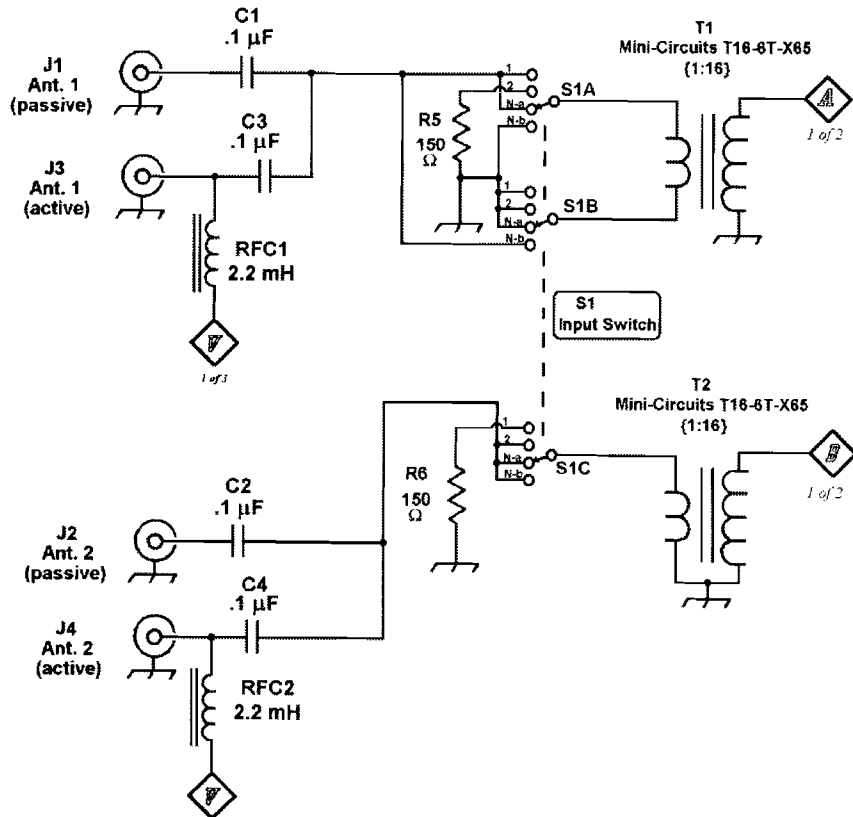

DXP-2
DXpedition Phasing Unit
Figure 2: Output Section

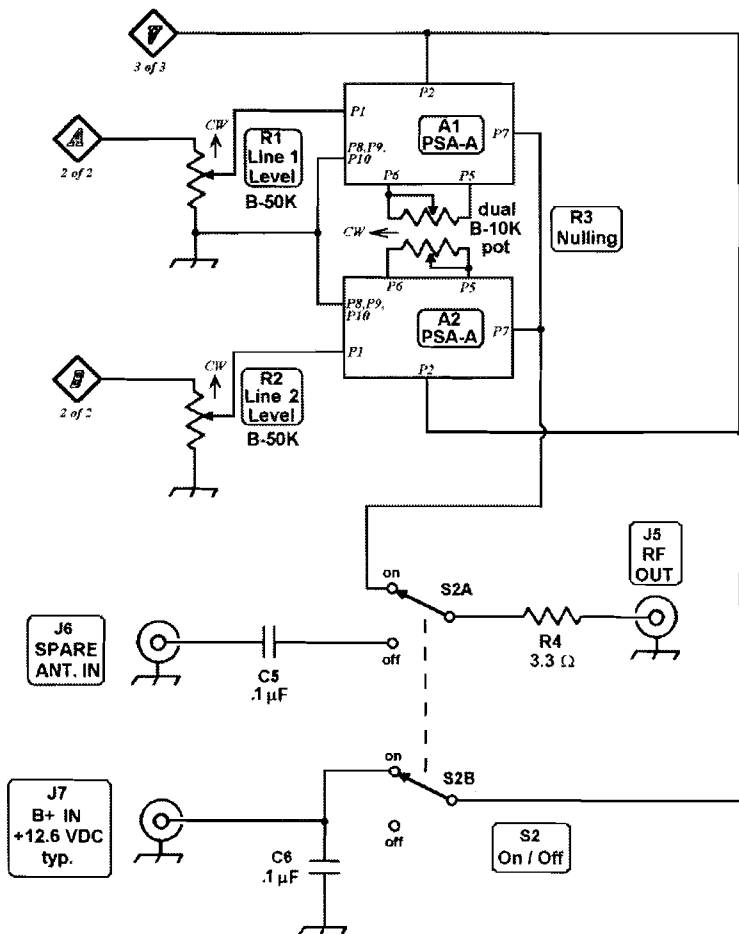

Are you expiring?

We hope not! To avoid expiration, mail your remittance to the *DX News* Membership Center early. Allow at least three weeks after mailing your check or money order for new renewal data to appear on your mailing label.

For NRC members only ...

Membership certificate, \$1.00
 Suitable for framing; red and blue print on white stock. Suitable for framing. Order item CERT from NRC Publications;
 NY orders, please add sales tax.

Problems, Problems?

We can't solve all your woes, but we can solve your *DX News* problems. Torn, soiled, partially-printed, MIA, or worst of all, delivered in a USPS plastic baggie? No need to return the copy - just end a postcard to NRC - 2840 SE Illinois Ave. - Topeka, KS 66605, or e-mail to <<plsBCBDXER@aol.com>> and a replacement copy will be mailed free. Missing a back issue? Replacement copies from Vol. 56 on, to current NRC members only, are sent for the cost of first-class postage. You joined in the middle of the year and need to fill out a volume? Send \$1.00 per copy (postage paid). Quantities can be sent at the Special Standard rate.

See? No problem!

Please preserve these QSL's for future display!
 Do not discard these items
 For preservation information contact the:
 National Radio Club
 P.O. Box 118
 Poquonock, Connecticut 06064

If you are interested in helping preserve the history of our hobby through preserving your collections, you should consider ordering a supply of these free 3-inch-square stickers to place on your veries, recordings, etc. Specify the number you need, and order from Ron Musco - P.O. Box 118 - Poquonock, CT 06064-0118. Include an SASE. Don't wait until it's too late - order now.

PSA-A Phase Shift Amplifier
 Drawing psa_a_f1: Schematic

NOTE: Typical range of phase-adjust pot. 0 to 180K ohms.

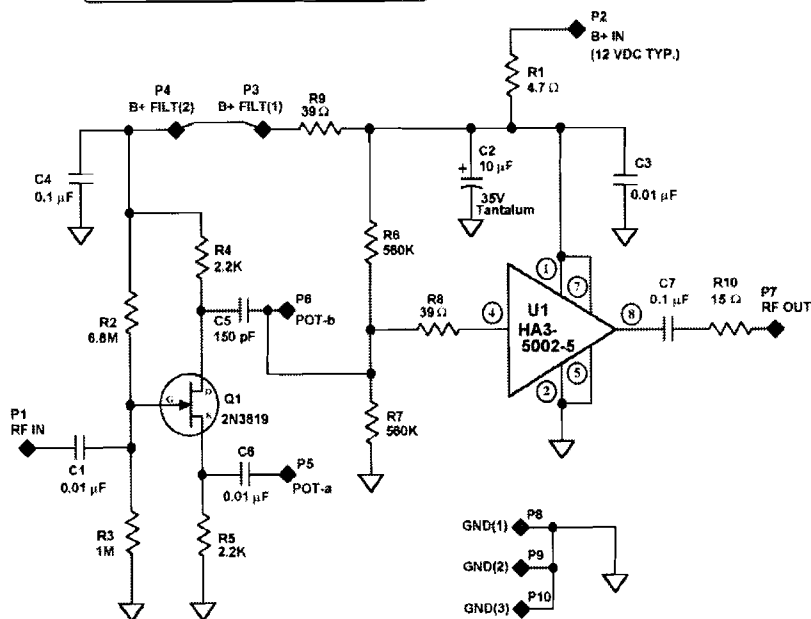

PSA-A Phase Shift Amplifier
 Drawing psa_a_f2: Assembly

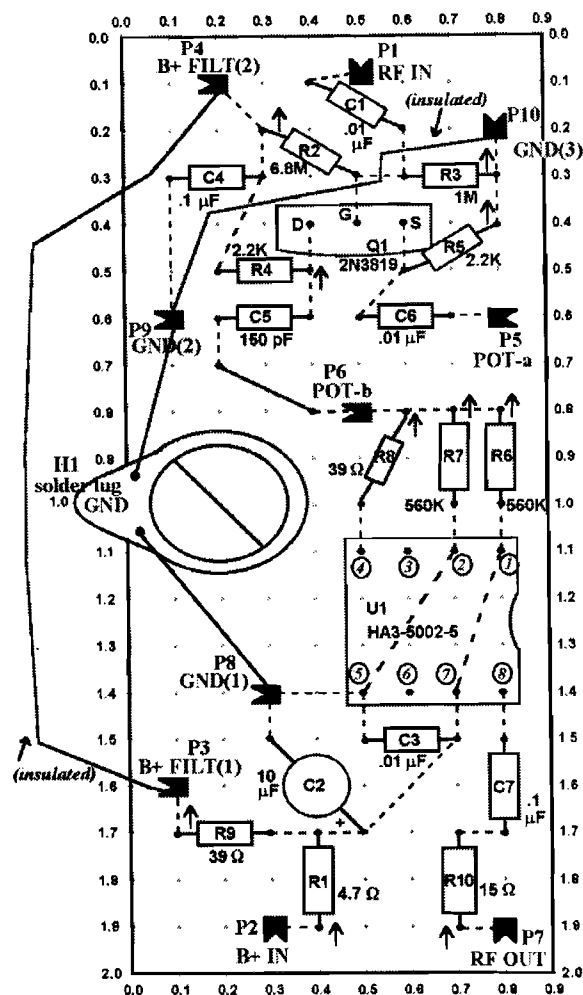

NOTES

- ↑ = Long lead side of vertically-mounted component
- - - = Buss wire on solder side of board
- = Buss wire on component side of board
- ◀ = "Flea clip" terminal pin
- OPEN SIDE

A DX'er's Technical Guide

Now in its 3rd edition (published early 1998), this 155-page book answers questions on receiver and antenna theory (how to improve their performance), how audio filters and loop antennas can improve DX (and hints on their construction), how to build a Beverage and phasing unit, and much more. Only \$10.00 for IRCA/NRC members, \$12.00 for non-members (overseas airmail add \$2.50). Order your copy today, in US funds payable to Phil Bytheway, from **IRCA Bookstore - 9705 Mary Ave. NW - Seattle, WA 98117-2334**

IRCA TIS LIST (2000)

COMPLETELY REVISED BY IRCA'S BILL HARMS TO 9/00, THE IRCA "TIS/HAR LIST" INCLUDES AM/FM AND TV LISTS FROM THE US AND CANADA. THIS 28 PAGE "DX AID" CAN BE YOURS FOR ONLY \$5.00. NON-IRCA/NRC MEMBERS... ADD \$1.00. OVERSEAS... ADD \$0.50. Order your copy today, in US funds payable to Phil Bytheway, from

IRCA Bookstore - 9705 Mary Ave. NW - Seattle, WA 98117-2334

IRCA AM Slogans List

Get in line NOW for your copy of the latest IRCA "AM SLOGANS LIST". Completely revised by IRCA's own Rich Toebe to 2/00 and including X-Band stations as well, this 24-page DX aid can be yours for only \$5.00. Non-NRC/IRCA members: add \$1.00. Overseas: add \$0.50. Order your copy today, in US funds payable to Phil Bytheway, from

IRCA Bookstore - 9705 Mary Ave. NW - Seattle, WA 98117-2334

Musings

of the Members

Thoughts from NRC members ... the opinions expressed in this column are those of the individual writer and do not necessarily reflect those of the editors, publishers, or the National Radio Club, Inc.

Dave Schmidt NRCMusings@aol.com
P. O. Box 3111
Scranton, PA 18505-0111

Times are local per Muse; submit double-spaced only.

A Brief, Incomplete History Of Radio

by Dan O'Day

(forwarded by Fred Vobbe)

A READER ASKS: "Following your advice in an earlier column, we've looked for and actually hired part-timers from several unusual places. (One was a waiter our GM had while trying to pitch a potential client, another a door-to-door salesman who came into the station lobby.) But when they get on the air, they seem to clam up and become much more boring than they were before we hired them. When training 'newly discovered' part-timers, what are the most important things to start with?"

DAN REPLIES: TELL THEM STORIES ... about how and why you got into radio, who influenced you, your best radio moments, what you still hope to achieve. War stories about broadcasting despite impossible conditions, accidentally locking yourself out of the studio, on-air flubs. Stories about personal connections that have been made with listeners: The girl who called to request her late grandmother's favorite song...The fan who sent you chocolate chip cookies on your birthday ... The listener who berated you for mispronouncing the name of his favorite artist. Stories about transistor radios under the bed covers and at the beach. Endless struggles to control the car radio buttons. "Would you PLEASE turn that down" and "Wait, I want to hear this!"

Novelty records and girl groups and Motown and Stax and Cadence and Elvis from the waist up and hearing "I Want To Hold Your Hand" for the very first time.

Stories about lovesick teenagers dedicating songs back and forth to each other. About children turning on the radio before they're even awake, feverishly hoping to hear those magic words from their local disc jockey: "No school, snow day..." About loneliness and a solitary voice reaching out to you. About making a complete stranger laugh or reflect or remember. About baseball games from far away on car radios. About someone driving across town or across country, with only you and your radio brethren for company.

Stories about Larry Lujack and John Records Landecker and Robert W. and Wolfman Jack and Gary Owens and Dr. Don and Kenny Everett (ask someone from the UK about Kenny) and those crazy young jocks who brought American-style radio to Europe in the 1960s by taking to the seas in honest-to-God pirate radio ships (imagine broadcasting under the worst possible conditions; now, imagine doing it while seasick). Stories about bad news and everyone immediately turning on the radio.

About sad news and where you were when you heard it. About practical jokes and misunderstandings and mild or wild revenge. About getting fired, packing up the U-Haul, and being scared all over again. Getting angry, getting older and "the good old days."

Static-y voices criss-crossing in the night. Fifteen-hour air shifts, flaky jocks, disappearing engineers. Stories about legendary radio people you almost met in an elevator at a convention. The major market PD who did you a favor; the request line caller you can't forget. Practical jokes on the news guy, disappearing stationery, and a bedroom full of promo records that one day will be worth something. Staying up late talking radio, swapping tapes, "borrowing" ideas, "embellishing" your ratings, deepening your voice, losing your voice, losing your place, losing your keys, losing your cool.

Wire service copy paper, 15-inch reels, pin-controlled automation. Caffeine addictions and junk food and whatever the station could trade for. Old friends, borrowed headphones, uncontrollable sleep-deprived laughter. Razor blades, splicing tape, grease pencils. Draping the tape edit over your shoulders until it was safe to throw away. Cue tones, cue sheets, in cue, out of breath. Slip-cueing, back-announcing, and hitting the post. Egos, rivals, and friendships. Imagination, excitement, Orson Welles and Jack Benny and Ma Perkins and Franklin D. Roosevelt and Arthur Godfrey and Don McNeil's Breakfast Club. Losing jobs, gaining weight, changing names. "How do they do that?" and "Listen to this!"

Storz, McClendon, Drake ... and Chuck Blore's Color Radio. Play-by-play and blow-by-blow; sports scores and election returns and Number One on the charts this week. 7-7-7, First Ticket, Hooper, Pulse, "You don't look anything like you sound!" "What am I doing with my life" and 7-day workweeks and "I can't believe I get paid for this!"

Slow starting turntables, nickel on the tone-arm, the cart machine sticks. Stories about hotlines, hot shots, skimmers, phantom cume, time checks, time warping, ratings, feelings, winning, showing off. T-shirts and coffee mugs and iridescent frisbees. Billboard and Claude Hall and Cashbox and Record World and R&R and Bill Gavin's green pages. Floods and tornado watches and power outages and school lunch menus. Lost dogs, lost accounts, lost tempers. Jiving, shouting, rhyming, whispering. Hiccup remedies, lemon 'n' honey, and good old-fashioned adrenalin to save the day. Embarrassed, elated, delighted. Hi-Low, Name It And Claim It, and Dollar-A-Holler.

Playlists and station surveys and Good Guys. Q, Zoo, and Boss. Bob and Ray and Mike and Elaine and The Monitor Beacon. Jingles, stickers, Chickenman and The Oidar Wavelength. Silly stunts, intense rivalries...Passion. B-Sides and label colors and songwriter credits. Favorite songs, favorite artists, favorite moments. Newspaper wars, live remotes, and meter readings. Shouts, stingers, sweepers, stagers, stabs. Make-goods, live tags, rip 'n' read and backtiming to the news. Allan Freed and Dan Ingram and Cousin Brucie. Beat the Bomb and Lucky Bucks and Battle of the Bands. Pinning the needle, pegging the meter, riding gain. Feedback and wrapping the capstan and "Hold on a sec, I gotta go on the air..."

Sign on, sign off, warming up the filament and Compression, Compression, Compression! Gates board with rotary pots; Automax and Volumemax. Intros, outros, ramps, talk-ups. False endings and records popping and skipping and carts jamming. Philosophical Differences and late night resumé photocopy sessions. Tight board, good pipes, will relocate. The big break, bad luck, skip waves, skipping town with the air staff's paychecks.

Cueing past the splice, heavy phones, cue burn. Solid Gold, Hot Nine at Nine, Hot 100. WABC and KHJ and KLIF and WOWO and WLS and making it to the big markets. Friday night countdowns, Saturday Swap Shops, Sunday drag racing commercials, twin spins, doubleplays, triple shots and instant replays.

Romantic entanglements, broken hearts, big dreams, small wins, and "Garbage Mouth Leaves Cleveland." "NO ONE is to touch these carts! And that means YOU!" "Were you listening when...?" and "What'd ya think?" and "You should have been there." Then explain to that new jock: Now you are there. What are you gonna do with it?

(And now it's your turn. What are YOUR favorite radio stories, from either side of the mike? As we have space in DXN, we'll reprint many of your stories (no bad words, now!) as we can cram in. Send them to Musings editor Dave Schmidt, along with your non-nostalgic Musings. Let's have some FUN with this! -pls.)

Are you expiring?

We hope not! To avoid expiration, mail your remittance to the DX News Membership Center early. Allow at least three weeks after mailing your check or money order for new renewal data to appear on your mailing label.

NRC Station Location Map Book

6th edition - \$12.00 to members
(\$17.95 non-members), postpaid.

Compiled by Bill Hale, this 239-page edition shows the location of all U. S. and Canadian broadcast stations (except TIS/LPRT) as well as latitude/longitude coordinates, plus instructions by Dave Sundius enabling users to calculate distance and bearing to any station. This 8.5x11-inch-sized book is three-hole punched for a letter-size ring binder. Order from NRC Publications - Box 164 - Mannsville, NY 13661. NY orders, please add sales tax.

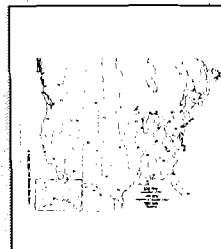

THE
DX'PEDITION
HANDBOOK

The DX'pedition Handbook ...

is simply all you need to plan your next DX'pedition. \$8.95 to NRC members, \$12.95 to non-members. Order from NRC Publications - Box 164 - Mannsville, NY 13661. NY orders, please add sales tax.